



Electronic Ball Valve Guide Specifications

Control Valve Assemblies

Ball Valve Bodies

All ball valves used for modulating or floating (tri-state) control must be furnished with a stainless steel ball & stem, RPTFE or PTFE seat seals and a high performance graphite impregnated stem seal that are rated for four times the modulation life of RTFE. Standard RTFE stem seals will not be acceptable. Two-way bronze bodies up to 3 inches must be rated for 600 PSI WOG, cold, non-shock service. Three-way bronze bodies up to 2 inches must be rated for 400 PSI WOG, cold, non-shock service. The valves must have a blowout proof stem design. Each valve must be tested by the valve manufacturer with air and under water at each end of travel. The stem packing gland must be adjustable to compensate for wear. Stem O-rings are not acceptable. Valve design must allow for disassembly of valve top, inspection and replacement of packing without system shutdown or valve body removal. Reduced port Cv's on valves must be set using a gauge and end stops. Modified balls which do not have equal percentage flow curves are not acceptable. Valves with nonmetallic characteristic discs are not acceptable.

Valve/Actuator Mounting

All ball valve actuator brackets must be metallic. Nonmetallic brackets are not acceptable. Mounting brackets must differ dimensionally for both "standard" and "high/low" temperature applications. Separation must be provided between the mounting bracket and electronic valve actuators to allow complete free air movement around the actuator to minimize heat transfer and condensation. Valve assemblies without the standoffs described above are not acceptable.

Application

Hot or Chilled Water

The pressure drop of the coil and the added pressure drop incurred when reducing the line size to the control valve (adjustment of the Cv for the Piping Geometry Factor, Fp) must be taken into consideration when sizing the valve. Three-way ball valves must be piped as diverting valves or mixing valves depending on the application. When used for coil applications, the valve must be piped before the coil (as a diverting valve) and not after the coil (as a mixing valve). The manufacturer's recommendations must be followed with regard to mounting, locating, insulating, wiring and applying the control valve assembly.

Steam

Ball valves may be used to control steam only when the complete assembly is specifically designed for high temperature applications. This applies to modulating applications up through 15 PSIG saturated steam and to two-position control applications up through 150 PSIG saturated steam. All seats and seals used for steam applications must be MTFE. Standard RTFE is not acceptable. Extra high brackets specifically designed for high temperature must be used. Brackets must separate the actuator from the valve body with a minimum of the following dimensions: for 1/2" to 1" valves a minimum of 4-5/8"; for 1-1/4" to 2" reduced port, and 1" and 1-1/4" full port valves a minimum of 6-1/2"; for full port valves 1-1/2" and larger and 3" reduced port a minimum of 5-1/2". All stem adapters between the valve stem and the electronic actuator must be close tolerance machined stainless or nickel plated steel, so as to provide low thermal conductivity and precise positioning throughout the full travel of the valve.

The manufacturer's recommendations must be followed with regard to mounting, locating, insulating, wiring and applying the products.



Valve Actuator - Commercial Type

The valve actuator must be capable of providing the minimum torque required for proper valve close-off for the application. Each actuator must have current limiting or stall detection circuitry incorporated into its design to prevent damage to the actuator. A gear release mechanism or manual override crank must be provided on all non-spring return motors to allow for manual override. Applications that require fail-safe operation of the valve assembly must use actuators with mechanical spring return or the addition of a centralized battery backup module at the control panel for ease of maintenance.

The actuator must be modulating, floating (tri-state) or two-position with spring return as called out in the control sequence of operation. All modulating valves must have positive positioning and respond to a 0(2)-10 VDC or a 0(4)-20 mA (with a dropping resistor) control signal. These modulating units must each have a position feedback signal corresponding to the actual valve position that can be wired back to the control system. An optional feedback potentiometer or auxiliary switch must be available, if required, for floating or two-position type actuators. All control valves must have a visual position indicator. The actuator must be powered by a 24 VAC, 120 VAC or 24 VDC signal. Actuators must be UL listed.

NEMA 4/4X type housing constructed of marine grade aluminum with an epoxy coating must be available as an option for all single actuator and dual assemblies. Field fabrication or non-NEMA 4/4X type enclosures are not acceptable.

The manufacturer must warranty the control valve assembly for a period of 2 years from the date of installation, not to exceed 30 months from the original date of shipment.

Control Valves must be provided by (DEI) Dodge Engineering and Controls, Chelmsford, MA.



Ball Valve Features

Stem Gland Nut
– Adjustable for wear



Stem Packing
– High performance
graphite impregnated
Teflon (MTFE)



Stem
– Blowout proof design



Stem Bearing
– Reinforced Teflon
(RPTFE) Thrust
Body



- Valve can be repacked without system shutdown or valve body removal
- High close-off capabilities
- Equal percentage flow characteristics
- High rangeability
- 600 PSI body rating for Two-Way valves
- 400 PSI body rating for Three-Way valves
- Industrial strength
- Self-cleaning
- Optional features include:
 - Stainless Steel Ball and Stem
 - Stainless Steel or Carbon Steel Bodies
 - Up to 2800 PSI body rating

Body
– Standard: Bronze
– Options: 316 S.S., Alloy-20 S.S., Carbon
Steel or Titanium & Nickel



Ball
– Chrome Plated Bronze or Steel, optional
Stainless Steel (316 or Alloy-20)



Seats
– Standard: Reinforced Teflon
(RPTFE) or Teflon (PTFE)
– MTFE for extreme temp.
applications



Retainer

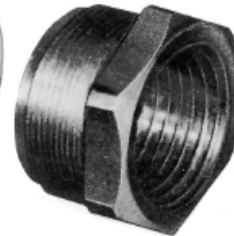

Note:

– All valves are tested with 100 PSI air under water, in open and closed positions.



Ball Valve Specifications

Flow Characteristics:	Two-Way: Equal Percentage, Three-Way: Linear		
Bronze Valve Body Rating:	600 PSI for Two-Way 400 PSI for Three-Way		
Operating Temperature:*	Refer to Temperature/Pressure curves (BV-5)		
Maximum Recommended Inlet Pressure:	Water: Temp./pressure curve (BV-5) Steam ("-HT" option only): Modulating: 15 PSIG (Sat.) Two-Position: 150 PSIG* (Sat.)		
Maximum Close-off Pressure:	Refer to Control Valve Close-Off Rating Charts (BV-6-7)		
Materials:	"Standard"	"-SBS"	"-HT"
Body	Bronze	Bronze	Bronze
Ball	Chrome Plated Brass	Stainless	Stainless
Stem	Brass	Stainless	Stainless
Stem Bearing	RPTFE	RPTFE	RPTFE
Packing	MTFE	MTFE	MTFE
Seat Seals	RPTFE or PTFE	RPTFE or PTFE	MTFE
Connections:	Threaded		

Notes:

- Special models are available for extreme temperature or chemical compatibility requirements.
- * Care must be taken to maintain the actuator's temperature limits as excess heat or condensation will cause premature failure.

———— **Percent of Maximum Flow vs. Percent of Ball Opening**
----- **Percent Heating Capacity (Hot Water Coil) vs. Percent**

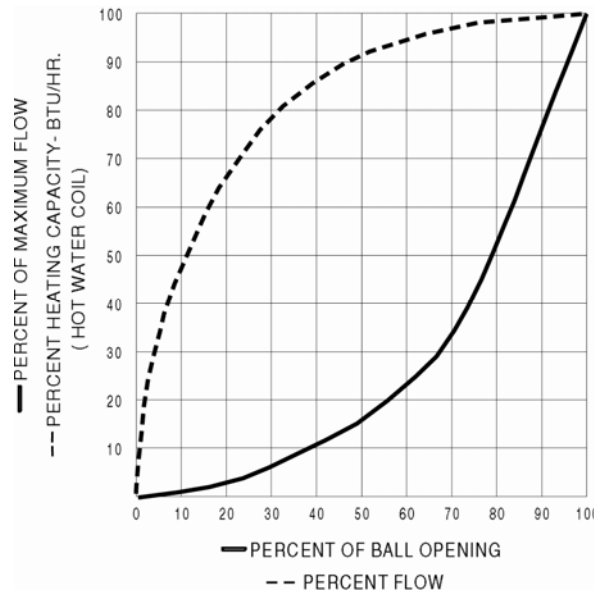

Note: The bottom curve indicates average Flow Characteristics for Two and Three-way Ball Valves. The top curve indicates average Coil Flow Characteristics.



Pressure / Temperature Ratings Two-Way Bronze Bodies (600 PSI)

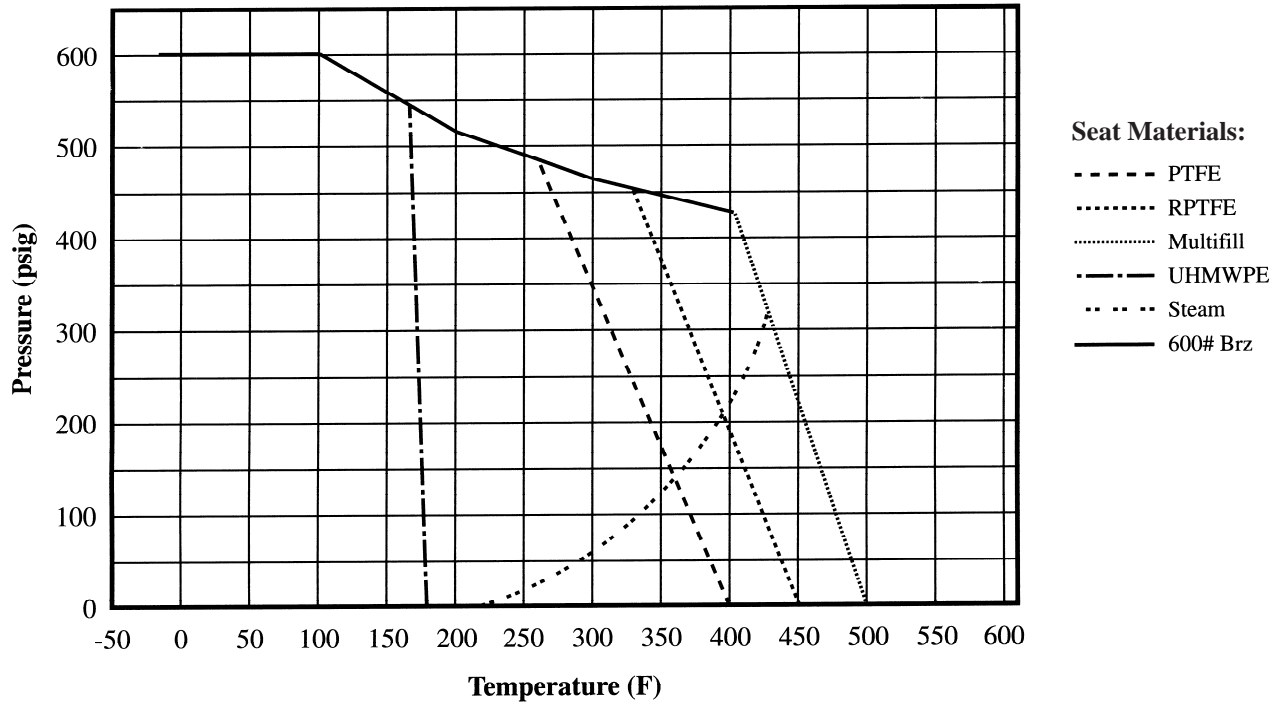

Pressure / Temperature Ratings Three-Way Bronze Bodies (400 PSI)

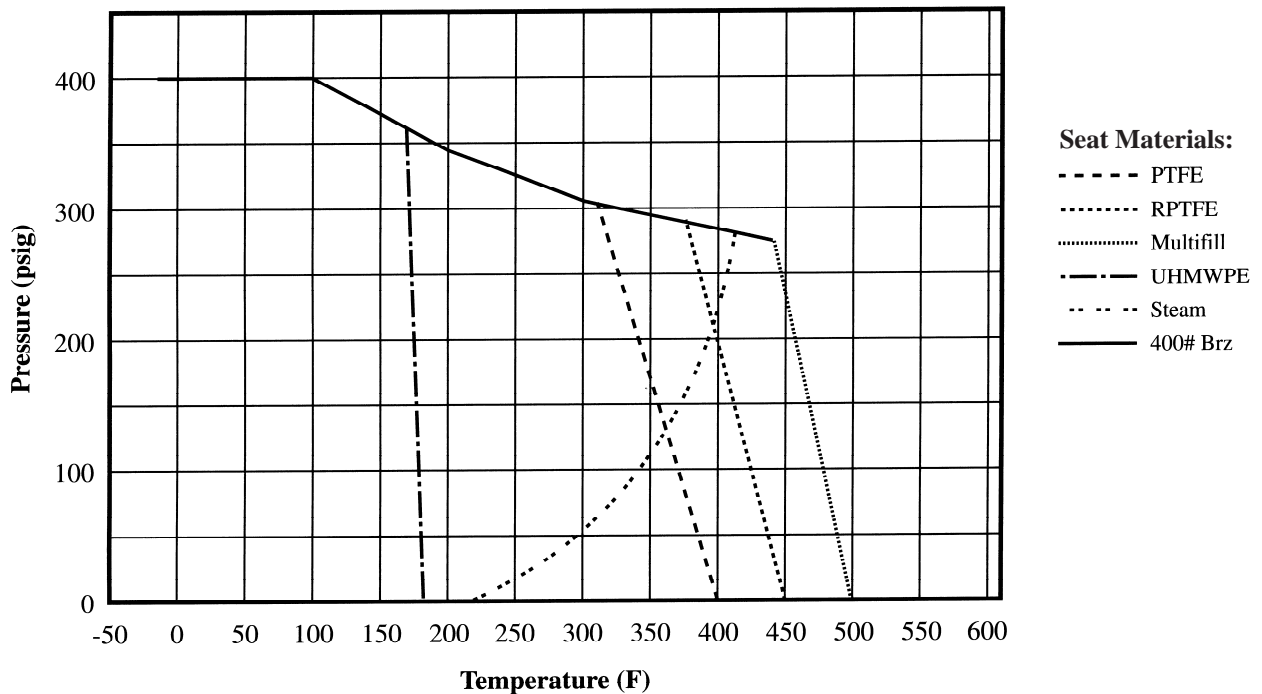



Control Valve Close-off Rating Chart

Two-Way Valves			CLOSE-OFF RATING (PSI Differential)**								
			Type A Non-Spring Return Motors (Actuator Type)						Type A Spring Return Motors (Actuator Type)		
NPT	CV	Model # [2 or 3-way] - [valve size] - [Cv]	EN44	EN88	EN132	EN221	EN310	Dual EN310	ES62	ES142	Dual ES142
1/2"	*	2-050-Cv	123	212	373	600	600	-	169	401	600
1/2"	9.8	2-050-9.8	123	212	373	600	600	-	169	401	600
3/4"	25	2-075-025	-	212	373	600	600	-	169	401	600
3/4"	33	2-075-033	-	143	283	474	600	-	-	305	600
1"	35	2-100-035	-	117	232	388	545	600	-	250	500
1"	47	2-100-047	-	-	118	198	280	559	-	128	351
1-1/4"	47	2-125-047	-	-	99	165	233	466	-	107	320
1-1/4"	81	2-125-081	-	-	-	98	139	278	-	64	128
1-1/2"	81	2-150-081	-	-	-	132	186	336	-	85	170
1-1/2"	105	2-150-105	-	-	-	-	104	208	-	-	95
2"	105	2-200-105	-	-	-	123	174	348	-	80	160
2"	360	2-200-360	-	-	-	-	90	180	-	-	80
2-1/2"	440	2-250-440	-	-	-	-	-	139	-	-	-
3"	390	2-300-390	-	-	-	-	-	139	-	-	-

Three-Way Valves			CLOSE-OFF RATING (PSI Differential)**								
			Type A Non-Spring Return Motors (Actuator Type)						Type A Spring Return Motors (Actuator Type)		
NPT	CV	Model # [2 or 3-way] - [valve size] - [Cv]	EN44	EN88	EN132	EN221	EN310	Dual EN310	ES62	ES142	Dual ES142
1/2"	*	3-050-Cv	123	212	298	400	-	-	169	400	-
1/2"	6	3-050-006	123	212	298	400	-	-	169	400	-
3/4"	12	3-075-012	-	212	298	400	-	-	169	400	-
1"	14	3-100-014	-	117	232	388	400	-	-	250	400
1-1/4"	22	3-125-022	-	-	99	166	233	400	-	107	320
1-1/2"	30	3-150-030	-	-	79	132	186	348	-	85	170
2"	50	3-200-050	-	-	-	-	81	163	-	-	74
2"	91	3-200-091	-	-	-	-	81	163	-	-	74

Notes:

- * Specify Cv in closest number when ordering reduced Cv (i.e., .5, 1, 2, 3... up to 5 for three-way and 9 for two-way).
- **All close-offs listed above are based on regularly modulated valves.
 - On 3/4" reduced port 2-way ball valves, the Cv can also be set for a Cv of 11 or 17.
 - All sizes indicated are available with DEI RE Series actuators for outside applications where NEMA 4 is required or where a higher close-off is required.
 - Add "-SBS" to end of model number if stainless ball and stem is desired (i.e., 2-050-9.8-SBS).
 - Add "-SBS-HT" to end of model number for steam applications.
 - Manual override handle is standard on larger non-spring models and optional on EN44 & EN88 models.



Control Valve Close-off Rating Chart

Two-Way Valves			CLOSE-OFF RATING (PSI Differential)**									
			Type B Non-Spring Return Motors (Actuator Type)						Type B Spring Return Motors (Actuator Type)			
NPT	CV	Model # [2 or 3-way] - [valve size] - [Cv]	EN53	EN70	EN140	EN210	EN280	Dual EN280	ES53	ES89	ES177	Dual ES177
1/2"	*	2-050-Cv	148	199	395	600	-	-	148	249	499	600
1/2"	9.8	2-050-9.8	148	199	395	600	-	-	148	249	499	600
3/4"	25	2-075-025	100	133	266	450	600	-	100	168	334	600
3/4"	33	2-075-033	-	133	266	450	600	-	-	168	334	600
1"	35	2-100-035	-	93	186	279	372	600	-	118	234	469
1"	47	2-100-047	-	-	126	189	252	504	-	-	159	319
1-1/4"	47	2-125-047	-	-	105	158	210	420	-	-	133	266
1-1/4"	81	2-125-081	-	-	62	93	124	247	-	-	78	156
1-1/2"	81	2-150-081	-	-	84	125	168	332	-	-	106	212
1-1/2"	105	2-150-105	-	-	-	88	117	234	-	-	-	148
2"	105	2-200-105	-	-	78	117	157	314	-	-	99	198
2"	360	2-200-360	-	-	-	-	81	162	-	-	-	102
2-1/2"	440	2-250-440	-	-	-	-	-	125	-	-	-	-
3"	390	2-300-390	-	-	-	-	-	125	-	-	-	-

Three-Way Valves			CLOSE-OFF RATING (PSI Differential)**									
			Type B Non-Spring Return Motors (Actuator Type)						Type B Spring Return Motors (Actuator Type)			
NPT	CV	Model # [2 or 3-way] - [valve size] - [Cv]	EN53	EN70	EN140	EN210	EN280	Dual EN280	ES53	ES89	ES177	Dual ES177
1/2"	*	3-050-Cv	148	199	395	400	-	-	148	249	400	-
1/2"	6	3-050-006	148	199	395	400	-	-	148	249	400	-
3/4"	12	3-075-012	100	133	266	400	-	-	100	168	379	400
1"	14	3-100-014	-	93	186	279	371	-	-	118	311	400
1-1/4"	22	3-125-022	-	-	105	158	210	400	-	-	133	266
1-1/2"	30	3-150-030	-	-	84	125	166	332	-	-	106	212
2"	50	3-200-050	-	-	-	-	73	146	-	-	-	92
2"	91	3-200-091	-	-	-	-	53	106	-	-	-	67

Notes:

- * Specify Cv in closest number when ordering reduced Cv (i.e., .5, 1, 2, 3... up to 5 for three-way and 9 for two-way).
- **All close-offs listed above are based on regularly modulated valves.
- On 3/4" reduced port 2-way ball valves, the Cv can also be set for a Cv of 11 or 17.
- All sizes indicated are available with DEI RE Series actuators for outside applications where NEMA 4 is required or where a higher close-off is required.
- Add "-SBS" to end of model number if stainless ball and stem is desired (i.e., 2-050-9.8-SBS).
- Add "-SBS-HT" to end of model number for steam applications.
- Manual override handle is standard on larger non-spring models and optional on EN53 models.



Two and Three –Way Commercial Electronic Ball Valves* (1/2” through 1” RP)

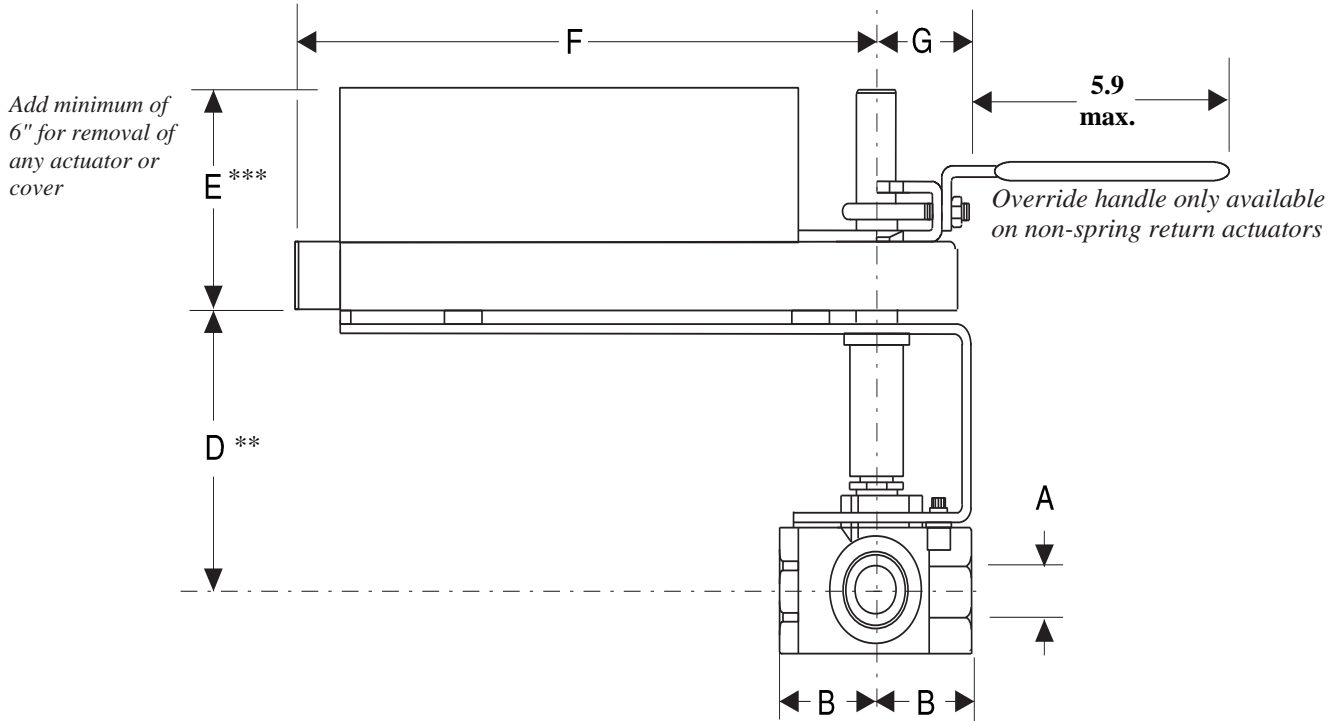

Two-Way Valve						
Size	Cv	Model No.	Dimensions (inches)			
			A	B	C†	D**
1/2" RP	****	2-050-Cv	0.5	1.1	NA	3.1
1/2" FP	9.8	2-050-9.8	0.5	1.1	NA	3.1
3/4" RP	25	2-075-025	0.7	1.5	NA	3.3
3/4" FP	33	2-075-033	0.8	1.6	NA	3.3
1"RP	35	2-100-035	0.9	1.7	NA	3.4
Three-Way Valve						
1/2" RP	****	3-050-Cv	0.5	1.1	1.2	3.1
1/2" RP	6	3-050-006	0.5	1.1	1.2	3.1
3/4" RP	12	3-075-012	0.7	1.5	1.6	3.3
1" RP	14	3-100-014	1.0	2.0	1.7	3.4

Actuator Selection Chart				
Actuator Type	Dimensions (inches)			
	E***	F	G	H‡
Type A Spring Return				
ES62	2.5	6.4	1.7	3.2
ES142	2.9	8.8	2.3	4.0
Type A Non-Spring Return				
EN44/88	2.4	3.8	1.7	2.8
EN132	2.5	6.4	1.7	3.2
EN221	2.9	8.8	2.3	4.0
Type B Spring Return				
ES52	3.2	7.4	1.3	3.3
ES53	3.6	5.7	1.6	3.3
ES89/177	3.2	8.2	2.2	4.0
ES140	3.5	7.7	2.2	4.6
Type B Non-Spring Return				
EN53	2.7	4.8	1.2	4.2
EN70/140	2.7	4.9	1.2	4.0
EN210/280	2.7	4.9	1.2	4.0

Notes:

- * See Actuator Selection Chart (AC-A-1&2 and AC-B-1&2) and Control Valve Close-off Rating Chart (BV-6&7) to select actuator.
- ** Add 2.3 inches to dimension "D" for "-HT" applications.
- *** Add 3" to dimension "E" for cover removal on Type B actuators.
- **** Limited Cv set to specifications (i.e.: .5, 1, 2, 3...).
- † "C" dimension is from center line of valve to face of port (three-way valves only).
- ‡ "H" dimension is width of motor.
- FP=Full Port, RP=Reduced Port.
- Most assemblies are available with an optional NEMA 4/4X type housing. See applicable data sheets for details.
- Add "-SBS" to end of model number if stainless ball and stem is desired (i.e., 2-050-9.8-SBS).



Two and Three –Way Commercial Electronic Ball Valves (1" FP through 2")

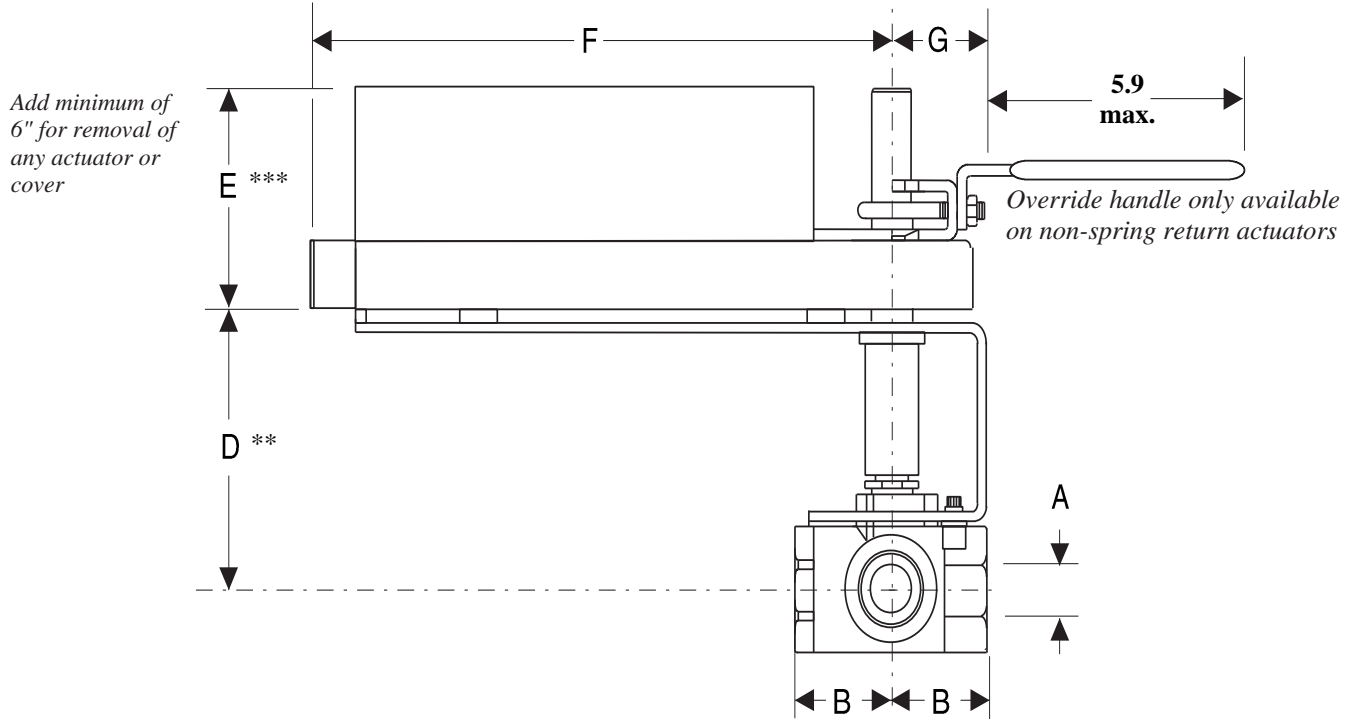

Two-Way Valve						
Size	Cv	Model No.	Dimensions (inches)			
			A	B	C†	D**
1" FP	47	2-100-047	1.0	1.8	NA	3.4
1-1/4" RP	47	2-125-047	1.0	2.0	NA	4.1
1-1/4" FP	81	2-125-081	1.3	2.1	NA	4.1
1-1/2" RP	81	2-150-081	1.3	2.2	NA	4.4
2" RP	105	2-200-105	1.5	2.4	NA	5.9
Three-Way Valve						
1-1/4" RP	22	3-125-022	1.0	2.0	2.4	4.1
1-1/2" RP	30	3-150-030	1.3	2.2	2.4	4.4
2" RP	50	3-200-050	1.5	2.4	2.5	5.9
2" FP	91	3-200-091	2.0	2.7	2.7	7.7

Actuator Selection Chart				
Actuator Type	Dimensions (inches)			
	E***	F	G	H‡
Type A Spring Return				
ES142	2.9	8.8	2.3	4.0
Type A Non-Spring Return				
EN132	2.5	6.4	1.7	3.2
EN221/310	2.9	8.8	2.3	4.0
Type B Spring Return				
ES89/177	3.2	8.2	2.2	4.0
ES140	3.5	7.7	2.2	4.6
Type B Non-Spring Return				
EN140/210/280	2.7	4.9	1.2	4.0

Notes:

- * See Actuator Selection Chart (AC-A-1&2 and AC-B-1&2) and Control Valve Close-off Rating Chart (BV-6&7) to select actuator.
- ** Add 4.0 inches to dimension "D" for "-HT" applications.
- *** Add 4.0 inches to dimension "E" for Dual actuator applications.
- † "C" dimension from center line of valve to face of port (three-way valves only).
- ‡ "H" dimension is width of motor.
- FP= Full Port, RP=Reduced Port.
- Most assemblies are available with an optional NEMA 4/4X type housing. See applicable data sheets for details.
- Add "-SBS" to end of model number if stainless ball and stem is desired (i.e., 2-050-9.8-SBS).



Two-Way Side Mount Commercial Electronic Ball Valves* (1-1/2" FP through 3" RP)

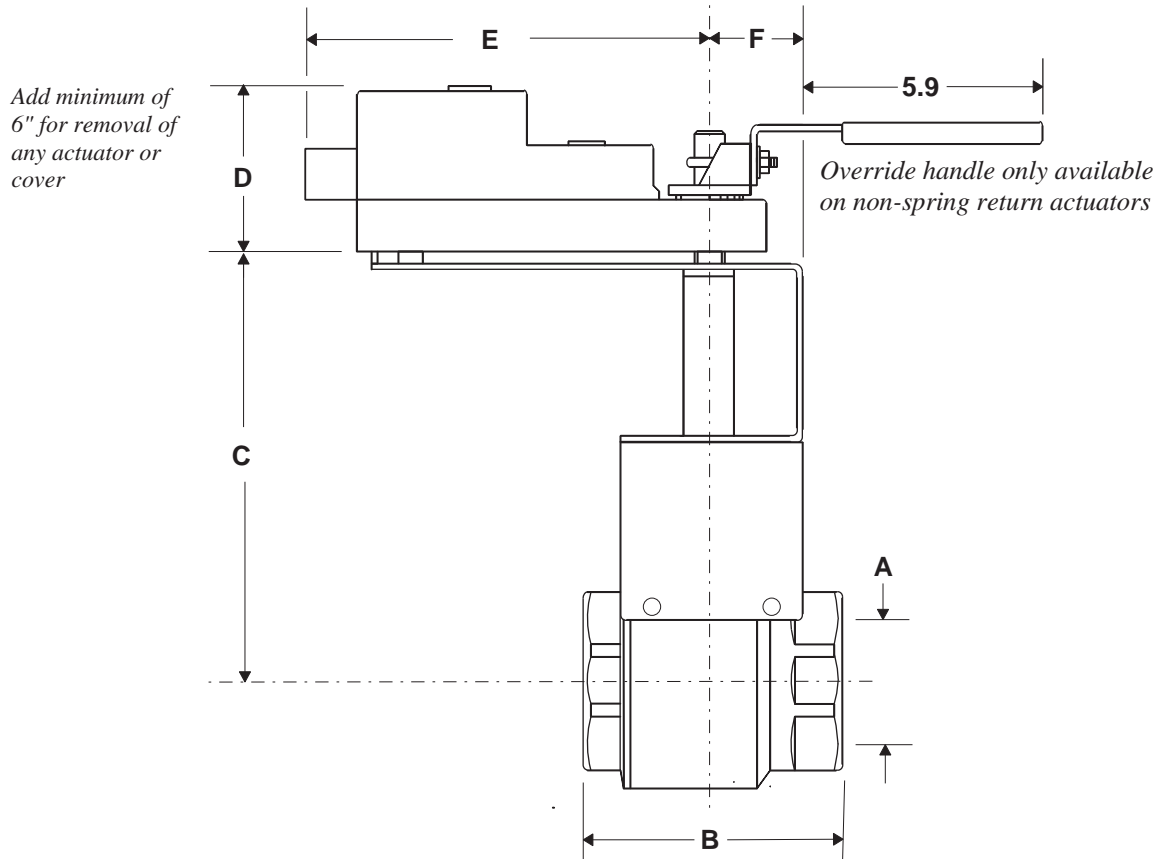

Two-Way Valve					
Size	Cv	Model No.	Dimensions (inches)		
			A	B	C**
1-1/2" FP	105	2-150-105	1.5	4.8	8.2
2" FP	360	2-200-360	2.0	5.4	8.5
2-1/2" FP	440	2-250-440	2.5	6.5	8.9
3" RP	390	2-300-390	2.5	6.8	8.9

Actuator Selection Chart				
Actuator Type	Dimensions (inches)			
	D***	E	F	G†
Type A Spring Return				
ES142	2.9	8.8	2.3	4.0
Type A Non-Spring Return				
EN310	2.9	8.8	2.3	4.0
Type B Spring Return				
ES140	3.5	7.7	2.2	4.6
ES177	3.2	8.2	2.2	4.0
Type B Non-Spring Return				
EN210/280	2.7	4.9	1.2	4.0

Notes:

- * See Actuator Selection Chart (AC-A-1-2 and AC-B-1-2) and Control Valve Close-off Rating Chart (BV-6-7) to select actuator.
- ** Dimensions in chart are valid for both standard and "-HT" applications.
- *** Add 4.0 inches to dimension "D" for dual actuator applications.
- † "G" dimension is width of motor.
- FP=Full Port, RP=Reduced Port.
- Most assemblies are available with an optional NEMA 4/4X type housing. See applicable data sheets for details.
- Add "-SBS" to end of model number if stainless ball and stem is desired (i.e., 2-050-9.8-SBS).



Electronic Ball Valves

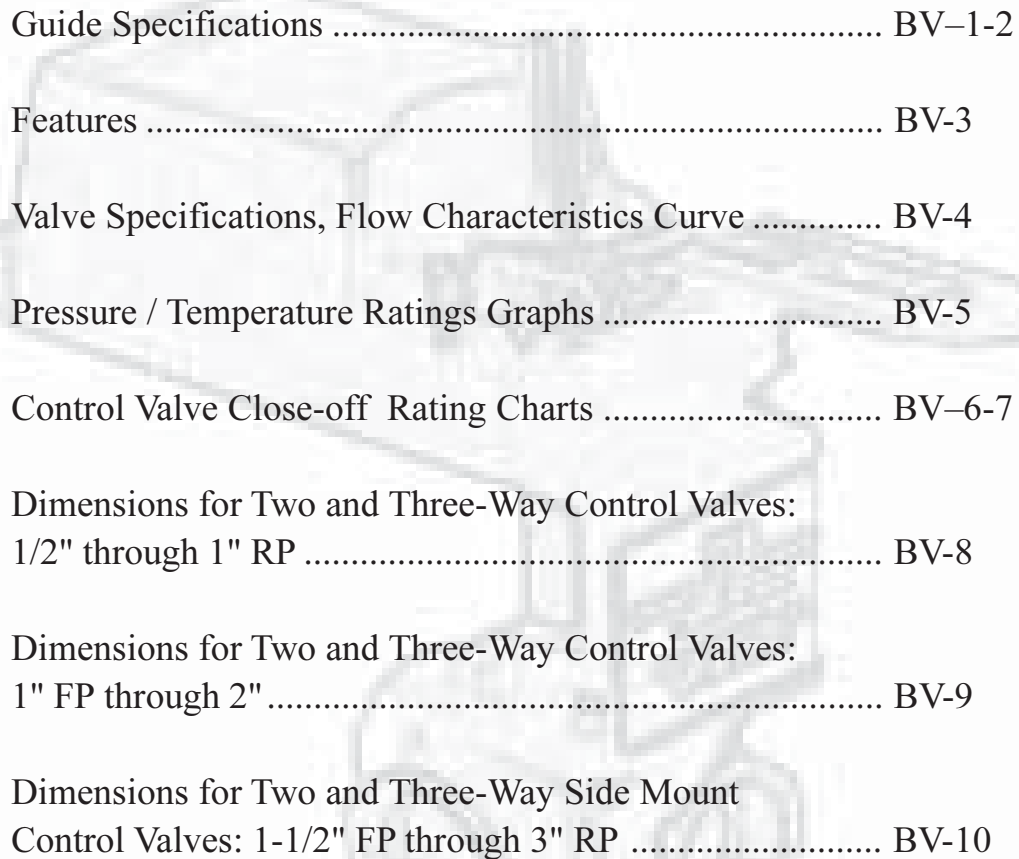

Guide Specifications	BV-1-2
Features	BV-3
Valve Specifications, Flow Characteristics Curve	BV-4
Pressure / Temperature Ratings Graphs	BV-5
Control Valve Close-off Rating Charts	BV-6-7
Dimensions for Two and Three-Way Control Valves: 1/2" through 1" RP	BV-8
Dimensions for Two and Three-Way Control Valves: 1" FP through 2"	BV-9
Dimensions for Two and Three-Way Side Mount Control Valves: 1-1/2" FP through 3" RP	BV-10