



Commercial Actuator Selection Chart – Non-Spring Return

Actuator Model	24 VAC Power Input	Control Signal						Position Feedback			Torque						Aux. Switches Built-in Auxiliary Switches, (-S) only
		On/Off	Tri-State Floating	0-10 VDC, 2-10 VDC 0-20 mA, 4-20 mA	Resistive: 100-10,000 Ohm	Pulse Width Modulation (PWM)	Starting Point & Span Adjust. (zero & span)	0-10 VDC, 2-10 VDC	Resistive (-P) 0-1000 Ohm	Resistive (-P2) 0-135 Ohm	35 in-lb	53 in-lb	70 in-lb	140 in-lb	210 in-lb	280 in-lb	
EN35C2(-N)/(-NDP)	•		•								•						
EN53A2(-S)	•	•	•									2					•
EN53B2(-S)	•			•		1		•				•					•
EN53C2(-S)	•		•									•					•
EN70B2(-S)	•			•		1		•					•				•
EN70B2-ZS(-S)	•			•			•	•					•				•
EN70C2(-S)	•	•	•										•				•
EN70C2(-P)/(-P2)	•	•	•					•	•				•				
EN70E2(-S)	•				•			•					•				•
EN140B2(-S)	•			•		1		•					•				•
EN140B2-ZS(-S)	•			•			•	•					•				•
EN140C2(-S)	•	•	•										•				•
EN140C2(-P)/(-P2)	•	•	•					•	•				•				
EN140E2(-S)	•				•			•					•				•
EN210B2(-S)	•			•		1		•						•			•
EN210B2-ZS(-S)	•			•			•	•						•			•
EN210C2(-S)	•	•	•											•			•
EN210C2(-P)/(-P2)	•	•	•					•	•					•			
EN210E2(-S)	•				•			•						•			•
EN280B2(-S)	•			•		1		•							•		•
EN280B2-ZS(-S)	•			•			•	•							•		•
EN280C2(-S)	•	•	•												•		•
EN280C2(-P)/(-P2)	•	•	•					•	•						•		
EN280E2(-S)	•				•			•							•		•

Notes:

- 1 Peripheral options are available for specialty signals such as PWM, 0-135 Ohm and 0-20 V phasecut. Call DEI.
- 2 For 1, 1.8 and 2 minute settings only. See page AC-B-6.
- Most commercial assemblies are available with an optional NEMA 4/4X type housing. See applicable data sheet for details.
- (-S) optional switch; (-P) optional resistive feedback; (-P2) optional resistive feedback; (-ZS) zero span version.



Commercial Actuator Selection Chart – Spring Return

Actuator Model	Power Input			Nominal Spring Return Time (Sec) - Maximum	Control Signal							Position Feedback			Torque		Built-in Auxiliary Switches (-S) only
	24 VAC	120 VAC	230 VAC		On/Off	Tri-State (Floating)	0-10 VDC, 2-10 VDC 0-20 mA, 4-20 mA	0-20 V Phasecut or 0-135 Ohm	Resistive: 100-10,000 Ohm	Pulse Width Modulation (PWM)	Starting Point & Span Adjust.	0-10 VDC, 2-10 VDC	Resistive (135 Ohm)	Resistive (1,000 Ohm)	53 in-lb	140 in-lb	
ES53A1		•		<15	•									•		•	
ES53A2(-S)	•			<15	•									•		•	
ES53B2(-S) ³	•			<15			2	1		1			•	•		•	
ES53C2(-S) ³	•			<15	•	•								•		•	
ES140A1(-S)		•		<15	•										•	•	
ES140A2(-S)	•			<15	•										•	•	
ES140A3(-S)			•	<15	•										•	•	
ES140B2(-S)	•			<15			•	1		1			•		•	•	
ES140B2-ZS(-S)	•			<15			•	1		1	•		•		•	•	
ES140C2(-S)	•			<15	•	•						•	•		•	•	
ES140E2(-S)	•			<15					•				•		•	•	

Notes:

- 1 Peripheral options are available for specialty signals such as PWM, 0-135 Ohm and 0-20 V phase cut. Call DEI.
- 2 2-10 V, 6-9 V or 4-20 mA only
- 3 (-MP) version is available with 20 VDC at 25 mA auxiliary power output used to power external devices, such as thermostats and controllers.
 - Most commercial assemblies are available with an optional NEMA 4/4X type housing. See applicable data sheet for details.
 - (-S) means the switch is optional.



Non-Spring Return 24 VAC Electronic Actuators, Tri-State (Floating)/Two-Position EN35C2-N & EN35C2-NDP (includes the DPT-2015 transmitter)

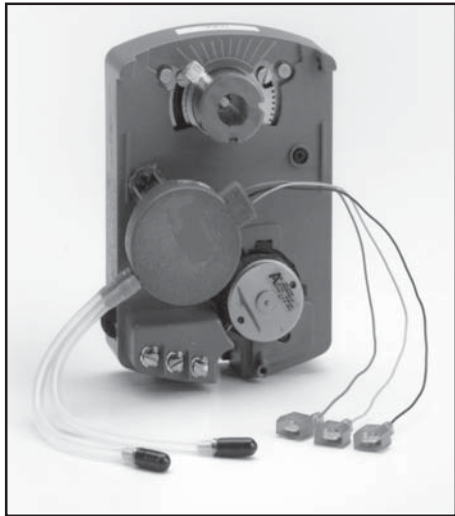

The EN35C2-N series synchronous motor-driven actuator provides floating (three-wire) control and is easily installed on a Variable Air Volume (VAV) box or small and medium-sized dampers with a round damper shaft up to 1/2 inch (13 mm) diameter or a 3/8 inch (10 mm) square shaft.

This compact, non-spring return actuator has a 35 in-lb (4 N-m) running torque and 40 in-lb (4.5 N-m) minimum stall torque in a compact easy-to-install package. It has a nominal 90-second travel time for 90° of rotation at 60 Hz (108 seconds at 50 Hz).

The EN35C2-NDP Actuator/Transmitter combines an EN35C2-N with a Differential Pressure Transmitter that has a 0 to 1.5 in. W.C. (0 to 374 Pa) differential pressure range.

Torque Minimum: 35 in-lb (4 N-m)

Application: The EN35C2-N is used to position round dampers and control dampers in typical HVAC applications. It is also used to position the blades in a VAV box. Refer to the damper or VAV box manufacturer's information to select the proper timing for the actuator. Refer to the appropriate application note for specific wiring diagrams and information.

Operation: The EN35C2-N provides a 35 in-lb (4 N-m) running torque and a minimum stall torque of 40 in-lb (4.5 N-m) for floating control of VAV box dampers.

The EN35C2-N mounts directly to the surface of a VAV box, round damper, or small rectangular damper with a single No. 10 self-drilling sheet metal screw (included). There are no additional linkages or couplers required. Clearly labeled electrical terminals simplify installation. When combined with a VAV controller, the EN35C2-N or EN35C2-NDP provides reliable, integrated damper control. The picture above shows the relationship of the actuator and the transmitter to the VAV box and controller.

A 24 VAC signal from the controller to the CW or CCW terminal of the actuator causes the motor to rotate in the proper direction and moves the damper blades open or closed. When the controller stops sending the signal, the actuator remains in place.

Note: To avoid excessive wear or drive time on the motor, use a controller and/or software that provides a time-out function to remove the signal at the end of rotation (stall).

The actuator rotates at a nominal rate of 1° per second (90° in 1.5 minutes). The actuator rotation is field adjustable from 30 to 90°. Actual rotation time for actuators, using less than 90° rotation, should be determined and that value used with the controller software. For example, 1 minute would be used for 60° rotation.

The EN35C2-NDP includes the DPT-2015 which is connected to the airflow pickup device of the VAV box. The DPT-2015 measures differential pressure and generates a proportional 0.5 to 4.5 VDC signal. The voltage signal from the DPT-2015 is read by the VAV controller and converted to airflow in cubic feet per minute (cfm). A wiring harness (ordered separately) is used to connect the transmitter and actuator to the VAV Series controller for simplified installation. Calibration is not required other than zero calibration, which is performed within the controller. The VAV controller must be provided with the correct "K" factor and VAV box size to perform the calculations.



**Non-Spring Return 24 VAC Electronic Actuators, Tri-State (Floating)
 EN35C2-N & EN35C2-NDP (includes the DPT-2015 transmitter)**

Technical Data	EN35C2-N/EN35C2-NDP	DPT-2015
Power supply	24 VAC (20 to 30 VAC) @ 50/60 Hz	15 VDC (14.5 to 17 VDC, unregulated 15 mA)
Transformer sizing	3.4 VA class 2 power source req. for UL	
Electrical connection	No. 6-32 screw terminals	1/4" spade terminals
DPT Pressure	-	0 to 1.5 in W.C. (0 to 374 Pa)
- Pressure range		15 in W.C. (3.74 kPa)
- Over pressure limit		0.5 to 4.5 VDC
- Output		
Pressure connections	-	6" (152 mm) length of silicone tubing with barbed fittings for 1/4" (6.35 mm) O.D. tubing
Angle of rotation	Adjustable from 30° to 90°	-
Torque	35 in-lb minimum	-
Direction of rotation	CW or CCW	-
Position indication	bolt indicator	-
Running time	90 secs @ 60 Hz 108 secs @ 50 Hz	-
Humidity	90% RH max, non-condensing	
Ambient temperature	32°F to 125°F (0°C to 52°C)	60°F to 100°F (16°C to 38°C)
Storage temperature	-20°F to 150°F (-29°C to 66°C)	
Housing type*	NEMA 1, IP30	
Agency listings	UL 873 listed; CSA C22.2, CE 89/336/EEC	
Servicing	maintenance free	
Quality standard	ISO 9002	
Weight	2.0 lbs (0.91 kg)	0.2 lbs (0.08 kg)

Wiring Diagrams

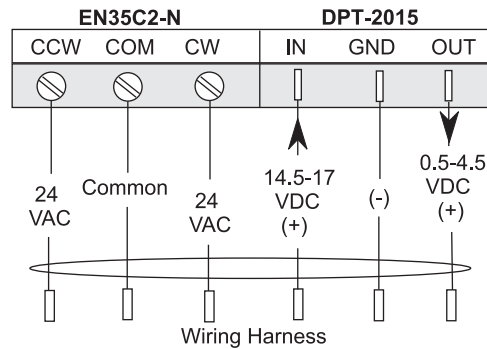

Note:

* Most commercial assemblies are available with an optional NEMA 4/4X type housing. See applicable data sheet for details.



Non-Spring Return, 24 VAC Electronic Actuators, Tri-State (Floating)/Two-Position EN53A2(-S), EN53C2(-S); EN70C2, EN140C2, EN210C2 & EN280C2(-S), (-P), (-P2)



EN53 Series Actuator

The EN "A" or "C" Series is a direct-mount line of actuators that operates on 24 VAC (or 24 VDC power for the EN70, 140, 210, and 280) and is available for use with floating controllers. The EN53 actuators are easily installed on a Variable Air Volume (VAV) box, a round damper shaft up to 1/2 inch (13 mm) diameter, and a 3/8 inch (10 mm) square shaft. The EN70, 140, 210 and 280 bidirectional actuators do not require a damper linkage and are easily installed on a round shaft up to a 3/4 inch (20 mm) diameter or a square shaft up to 5/8 inch (16 mm).

All actuators can also be mounted to valves (ball, globe, and butterfly) using one of the many valve linkage kits available through Dodge Engineering & Controls.

The EN models deliver up to 280 in-lb (32 N-m) of torque in a single mount configuration, and up to 560 in-lb (64 N-m) of torque in a tandem mount configuration. The angle of rotation is mechanically adjustable from 0° to 90° in 5° increments. Integral auxiliary switches are available to indicate end-stop position or to perform switching functions at any angle within the selected rotation range. Position feedback is available through switches or a potentiometer signal.



EN70, 140, 210, 280 Series Actuator

Torque Minimum: EN53A2 or EN53C2: 53 in-lb; EN70C2: 70 in-lb; EN140C2: 140 in-lb; EN210C2: 210 in-lb; EN280C2: 280 in-lb

Application: EN Series actuators are designed to position air dampers and valves in HVAC systems. Applications include: positioning return air or exhaust dampers; controlling face and bypass dampers; positioning blades for variable volume fans; positioning ball, butterfly or globe valves. Refer to the manufacturer's information to size properly the damper, valve and/or actuator. Spring return actuators, such as Dodge Engineering's ES Series, are recommended for use with outdoor air dampers in cold climates.

Operation (EN53): The EN53 Series provides a 53 in-lb (6 N-m) running torque for floating control of dampers, VAV box dampers or control valves. The EN53 Series mounts directly on the duct surface, round damper or small rectangular damper with an anti-rotation bracket and two sheet metal screws (included). Additional linkages or couplers are not required. A controller provides a control signal to the actuator depending upon the desired movement of the damper blade. This signal causes the motor to rotate in the proper direction and moves the damper blade open or closed.

Note: To avoid excessive wear or drive time on the motor, use a controller and/or software that provides a time-out function to remove the signal at the end of rotation (stall).

The EN53C2(-S) actuator rotates at a nominal rate of 1.5° per second (90° in 60 seconds) at 60 Hz input (72 seconds @ 50 Hz) with a load independent rotation time. The actuator rotation is field adjustable from 30° to 90°. Actual rotation time for actuators using less than 90° rotation should be determined and that value used with the controller software. For example, 40 seconds would be used for 60° rotation. The EN53A2(-S) models offer adjustable rotation times of 1, 1.5, 2, 5.5 and 11 minutes. The 1, 1.5 and 2 minute settings provide 53 in-lb of torque and are ideal for two-position and floating applications. The 5.5 and 11 minute settings provide 35 in-lb of torque.

Operation (EN70, 140, 210 and 280): EN Series actuators operate on 24 VAC at 50/60 Hz or 24 VDC. These compact actuators use a DC motor with stall detection circuitry that operates throughout the entire stroke. The proportional actuators employ noise filtering techniques on the control signal to eliminate response to spurious noise. Rotation is mechanically limited to 93° by integral end-stops. The position of the actuator is visually indicated from 0° to 90° on the cover. An anti-rotation bracket prevents lateral movement of the actuator. For hand positioning the coupler, pressing the spring-loaded gear release on the actuator cover can manually disengage the gear train.



**Non-Spring Return, 24 VAC Electronic Actuators, Tri-State (Floating)/Two-Position
EN53A2(-S), EN53C2(-S); EN70C2, EN140C2, EN210C2 & EN280C2(-S), (-P), (-P2)**

Technical Data	EN53C2(-S), EN53A2(-S)	EN70C2 (-S)(-P)(-P2)	EN140C2 (-S)(-P)(-P2)	EN210C2 (-S)(-P)(-P2)	EN280C2 (-S)(-P)(-P2)
Power supply	20 to 30 VAC @ 50/60 Hz	20 to 30 VAC, 24 VDC +/- 10%, 50/60 Hz			
Transformer sizing	C2(-S) ¹ : 2.5 VA A2(-S) ² : 2.8 VA (class 2 power source req. for UL)	6.5 VA (class 2 power source req. for UL)		7.5 VA (class 2 power source req. for UL)	
Electrical connection	1/4" spade terminals**	screw terminals for 22 to 14 AWG (max of two 18-22 AWG/terminals)			
Control signal	C2(-S): floating A2(-S): two-position or floating 20-30 VAC @ 50/60 Hz	floating (20 to 30 VAC at 50/60 Hz)			24 VAC @ 50/60 Hz or 24 VDC
Factory setting	Direct (CW) or reverse (CCW) with signal increase (jumper selectable)				
Feedback signal (-P) or (-P2) option	-	1000 Ω (-P) or 135 Ω (-P2)			
Input impedance	C2(-S) ¹ : 200 Ω A2(-S) ² : 160 Ω	400 Ω			
Switch contact rating (-S) option	Two SPDT rated @ 24 VAC, 1.5 A inductive, 3 A resistive, 35 VA max per switch, class 2				
Mechanical connection (shaft size)	3/8" to 1/2" (10-12.7 mm) diameter round shaft 3/8" (10 mm) square shaft	3/8" to 3/4" (10-20 mm) diameter round shaft 3/8" to 5/8" (10-16 mm) square shaft			
Angle of rotation	Adjustable from 30-90°	0-90° in 5° increments, mechanical limitation 93°			
Torque	1, 1.5, and 2 minute settings: 53 in-lb (6 N-m) 5.5 and 11 minute settings: 35 in-lb (4 N-m)	70 in-lb (8 N-m)	140 in-lb (16 N-m)	210 in-lb (24 N-m)	280 in-lb (32 N-m)
Direction of rotation	CW or CCW	CW or CCW with proper wiring			
Position indication	bolt indicator	clip-on indicator			
Running time	C2(-S) ¹ : 60 secs @ 60 Hz, 72 secs @ 50 Hz A2(-S) ² : 60 secs factory set, adjustable with switch: 60, 90, 120, 330, or 660 secs @ 60 Hz, 72, 108, 144, 396, or 792 secs @ 50 Hz	25-50 secs for 0-70 in-lb (0-8 N-m)	70-115 secs for 0-140 in-lb (0-16 N-m)	115-175 secs for 0-210 in-lb (0-24 N-m)	115-185 secs for 0-280 (0-32 N-m)
Humidity	0 to 90% RH non-condensing	0 to 95% RH non-condensing			
Operating temperature	-4°F to 125°F (-20°C to 52°C)	-4°F to 122°F (-20°C to 50°C)			
Storage temperature	C2(-S) ¹ : -40°F to 176°F (-40°C to 80°C) A2(-S) ² : -40°F to 186°F (-40°C to 86°C)	-40°F to 186°F (-40°C to 86°C)			
Housing type*	NEMA 2, IP32	NEMA 2, IP42			
Agency listings	UL 873 listed; CSA C22.2, CE 89/336/EEC				
Noise level	<35 dBA @ 1 m	<45 dBA @ 1 m			
Servicing	maintenance free				
Quality standard	ISO 9002				
Weight	2.4 lbs (1.08 kg)	2.9 lbs (1.3 kg)			

Notes:

- * Most commercial assemblies are available with an optional NEMA 4/4X type housing. See applicable data sheet for details.
- ** Optional pluggable terminal blocks.
- 1 Tri-State only
- 2 Two-Position or Tri-State



**Non-Spring Return, 24 VAC Electronic Actuators, Tri-State (Floating)/Two-Position
 EN53A2(-S), EN53C2(-S); EN70C2, EN140C2, EN210C2 & EN280C2(-S), (-P), (-P2)**

Wiring Diagrams

EN53C2(-S) and EN53A2(-S)

Floating Control

Models: EN53C2 and EN53C2-S
 EN53A2 and EN53A2-S

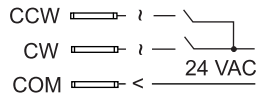

Auxiliary Switches

Models: EN53C2-S and EN53A2-S

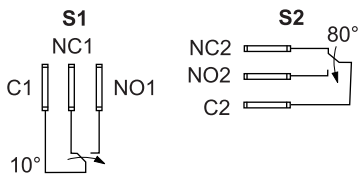

Two-position Control

Models: A2 and A2-S

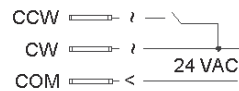

EN70C2, EN140C2, EN210C2 & EN280C2(-S), (-P), (-P2)

Terminal Block 1

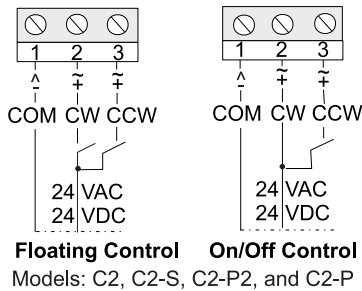

Terminal Block 2

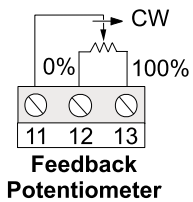
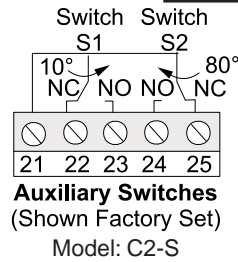

Models: C2-P2 = 0-135 ohms
 C2-P = 0-1000 ohms



Non-Spring Return, 24 VAC/VDC Electronic Actuators, Modulating EN53B2(-S), EN70B2(-S)(-ZS), EN140B2(-S)(-ZS), EN210B2(-S)(-ZS), & EN280B2(-S)



EN53 Series Actuator

The "EN" Series is a direct-mount line of actuators that operates on 24 VAC (for all models) or 24 VDC for the EN70, 140, 210 and 280 models and is available for use with proportional controllers. The EN53 actuators are easily installed on a Variable Air Volume (VAV) box, a round damper shaft up to 1/2" (13 mm) diameter, and a 3/8" (10 mm) square shaft. The EN70, 140, 210 and 280 bidirectional actuators do not require a damper linkage and are easily installed on a round shaft up to 3/4" (20 mm) diameter or a square shaft up to 5/8" (16 mm). All actuators can also be mounted to valves (ball, globe, and butterfly) using one of the many valve linkage kits available through Dodge Engineering & Controls.

The EN models deliver up to 280 in-lb (32 N-m) of torque. The angle of rotation is mechanically adjustable from 0° to 90° in 5° increments. Integral auxiliary switches are available to indicate end-stop position or to perform switching functions at any angle within the selected rotation range. Position feedback is available through switches or a 0 (2) to 10 VDC signal.

Torque Minimum: EN53B2: 53 in-lb; EN70B2: 70 in-lb; EN140B2: 140 in-lb; EN210B2: 210 in-lb; EN280B2: 280 in-lb



EN70, 140, 210, 280 Series Actuator

Application: EN Series actuators are designed to position air dampers and valves in HVAC systems. Applications include: positioning return air or exhaust dampers; controlling face and bypass dampers; positioning blades for variable volume fans; positioning ball, butterfly or globe valves. Refer to the manufacturer's information to size properly the damper, valve and/or actuator. Spring return actuators, such as Dodge Engineering's ES Series, are recommended for use with outdoor air dampers in cold climates.

Operation (EN53): The EN53 Series provides a 53 in-lb (6 N-m) running torque for proportional control of dampers, VAV box dampers or control valves. The EN53 Series mounts directly on the duct surface, round damper or small rectangular damper with an anti-rotation bracket and two sheet metal screws (included). Additional linkages or couplers are not required. A controller provides a control signal to the actuator depending upon the desired movement of the damper blade. This signal causes the motor to rotate in the proper direction and moves the damper blade open or closed.

Note: To avoid excessive wear or drive time on the motor, use a controller and/or software that provides a time-out function to remove the signal at the end of rotation (stall).

The actuator rotates at a nominal rate of 1.5° per second (90° in 60 seconds) at 60 Hz input. The actuator rotation is field adjustable from 30° to 90°. Actual rotation time for actuators

using less than 90° rotation should be determined and that value used with the controller software. For example, 40 seconds would be used for 60° rotation.

Operation (EN70, 140, 210, 280): EN Series actuators operate on 24 VAC at 50/60 Hz or 24 VDC. These compact actuators use a DC motor with stall detection circuitry that operates throughout the entire stroke. The proportional actuators employ noise filtering techniques on the control signal to eliminate response to spurious noise. Rotation is mechanically limited to 93° by integral end-stops. The position of the actuator is visually indicated from 0° to 90° on the cover. An anti-rotation bracket prevents lateral movement of the actuator. For hand positioning the coupler, pressing the spring-loaded gear release on the actuator cover can manually disengage the gear train.



Non-Spring Return, 24 VAC/VDC Electronic Actuators, Modulating EN53B2(-S), EN70B2(-S)(-ZS), EN140B2(-S)(-ZS), EN210B2(-S)(-ZS), & EN280B2(-S)

Technical Data	EN53B2(-S)	EN70B2(-S)(-ZS)	EN140B2(-S)(-ZS)	EN210B2(-S)(-ZS)	EN280B2(-S)
Power supply	20 to 30 VAC @ 50/60 Hz	20 to 30 VAC, 24 VDC ±10%, 50/60 Hz			
Transformer sizing	3.2 VA class 2 power source req. for UL	7.5 VA class 2 power source req. for UL			
Electrical connection	1/4" spade terminals**	screw terminals for 22 to 14 AWG (max of two 18-22 AWG/terminals)			
Control signal	0(2) to 10 VDC, 0(2) to 20 VDC, or 0(4) to 20 mA (jumper selectable)				
Control signal (-ZS option)	-	zero; 0-6 VDC, 0-12 VDC, or 0-12 mA span; 2-10 VDC, 4-20 VDC, or 4-20 mA			-
Factory setting	0-10 VDC direct CW rotation with signal increase	0-10 VDC, 0-20 mA, CW rotation with signal increase			
Feedback signal	0-10 VDC or 2-10 VDC for 90° (1 mA @ 10 VDC) (corresponds to input and signal span selection)				
Input impedance	voltage: 150 kΩ, current: 500 Ω	voltage: 205 kΩ for 0(2) to 10 V, 410 kΩ for 0(4) to 20 V, current: 500 Ω			
Switch contact rating (-S option)	two SPDT rated at 24 VAC, 1.5 A inductive, 3 A resistive 35 VA max per switch				
Mechanical connection (shaft size)	3/8" to 1/2" (10 mm to 12.7 mm) diameter round shaft 3/8" (10 mm) square shaft	3/8" to 3/4" (10 mm to 20 mm) diameter round shaft 3/8" to 5/8" (10 mm to 16 mm) square shaft			
Angle of rotation	adjustable from 30°-90°	0°-90° in 5° increments, mechanical limitation 93°			
Torque	53 in-lb (6 N-m)	70 in-lb (8 N-m) constant	140 in-lb (16 N-m)	210 in-lb (24 N-m)	280 in-lb (32 N-m)
Direction of rotation	CW or CCW	jumper selectable			
Position indication	clip-on indicator				
Running time	60 secs @ 60 Hz, 72 secs @ 50 Hz	25-50 secs for 0-70 in-lb (0-8 N-m)	70-115 secs for 0-140 in-lb (0-16 N-m)	115-175 secs for 0-210 in-lb (0-24 N-m)	115-185 secs for 0-280 in-lb (0-32 N-m)
Humidity	0 to 95% RH non-condensing				
Ambient temperature	-4°F to 125°F (-20°C to 52°C)				
Storage temperature	-40°F to 176°F (-40°C to 86°C)				
Housing type*	NEMA 2, IP32				
Agency listing	UL873 listed, CSA C22.2, CE 89/336/EEC				
Noise level	≤ 35 dBA @ 1 m	≤ 45 dBA @ 1 m			
Servicing	maintenance free				
Quality standard	ISO 9002				
Weight	2.4 lbs (1.08 kg)	2.9 lbs (1.3 kg)			

Notes:

- * Most commercial assemblies are available with an optional NEMA 4/4X type housing. See applicable data sheet for details.
- ** Optional pluggable terminal blocks.



Non-Spring Return 24 VAC/VDC Electronic Actuators, Resistive EN70E2(-S), EN140E2(-S) & EN210E2(-S)



The EN "E" Series is a direct-mount line of actuators that operates on 24 VAC or VDC power and is available for use with resistive controllers. These bidirectional actuators do not require a damper linkage and are easily installed on a round shaft up to a 3/4" (20 mm) diameter or a square shaft up to 5/8" (16 mm). They can also be mounted to valves (ball, globe, and butterfly) using one of the many valve linkage kits available through Dodge Engineering & Controls.

The EN models deliver up to 210 in-lb (24 N-m) of torque. The angle of rotation is mechanically adjustable from 0° to 90° in 5° increments. Integral auxiliary switches are available to indicate end-stop position or to perform switching functions at any angle within the selected rotation range. Position feedback is available through switches or a 0 (2) to 10 VDC signal.

Torque Minimum: EN70E2: 70 in-lb; EN140E2: 140 in-lb; EN210E2: 210 in-lb.

Application: EN Series actuators are designed to position air dampers and valves in HVAC systems. Applications include: positioning return air or exhaust dampers; controlling face and bypass dampers; positioning blades for variable volume fans; positioning ball, butterfly or globe valves. Refer to the manufacturer's information to size properly the damper, valve and/or actuator. Spring return actuators, such as Dodge Engineering's ES Series, are recommended for use with outdoor air dampers in cold climates.

Operation: EN Series actuators operate on 24 VAC at 50/60 Hz or 24 VDC. These compact actuators use a DC motor with stall detection circuitry that operates throughout the entire stroke. The resistive actuators employ noise filtering techniques on the control signal to eliminate response to spurious noise.

Rotation is mechanically limited to 93° by integral end-stops. The position of the actuator is visually indicated from 0° to 90° on the cover. An anti-rotation bracket prevents lateral movement of the actuator. For hand positioning the coupler, pressing the spring-loaded gear release on the actuator cover can manually disengage the gear train.



Non-Spring Return 24 VAC/VDC Electronic Actuators, Resistive EN70E2, EN140E2 & EN210E2(-S)

Technical Data	EN70E2(-S)	EN140E2(-S)	EN210E2(-S)
Power supply	20 to 30 VAC, 24 VDC ±10%, 50/60 Hz		
Transformer sizing	7.5 VA class 2 power source req. for UL		
Electrical connection	screw terminals for 22 to 14 AWG (max. of two 18-22 AWG/terminals)		
Control signal	100 to 10,000 Ω		
Factory setting	direct (CW) with signal increase		
Feedback signal	0 to 10 VDC for 90° (1 mA at 10 VDC)		
Input impedance	1.8 MΩ		
Switch contact rating (-S option)	two SPDT rated @ 24 VAC, 1.5 A inductive, 3 A resistive (3.5 VA max. per switch)		
Mechanical connection (shaft size)	3/8" to 3/4" (10 mm to 20 mm) diameter round shaft 3/8" to 5/8" (10 mm to 16 mm) square shaft		
Angle of rotation	0° to 90° in 5° increments, mechanical limitation 93°		
Torque	70 in-lb (8 N-m) constant	140 in-lb (16 N-m)	210 in-lb (24 N-m)
Direction of rotation	jumper selectable		
Position indication	clip-on indicator		
Running time	25-50 secs for 0-70 in-lb (0-8 N-m)	70-115 secs For 0-140 in-lb (0-16 N-m)	115-175 secs For 0-210 in-lb (0-24 N-m)
Humidity	0 to 95% RH non-condensing		
Ambient temperature	-40°F to 122°F (-20°C to 50°C)		
Storage temperature	-40°F to 186°F (-40°C to 86°C)		
Housing type*	NEMA 2, IP42		
Agency listings	UL 873 listed; CSA C22.2, CE 89/336/EEC		
Noise level	<45 dBA @ 1 m		
Servicing	maintenance free		
Quality standard	ISO 9002		
Weight	2.9 lbs (1.3 kg)		

Note:

- * Most commercial assemblies are available with an optional NEMA 4/4X type housing. See applicable data sheet for details.

Wiring Diagrams

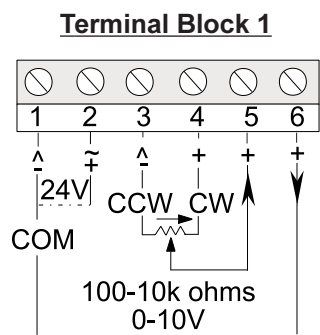

Resistive Input Control
 Models: E2 and E2-S

Note:

Terminals 3 and 4 function as CCW and CW references when the Resistive models are in the DA mode, but as CW and CCW references when these models are in the RA mode.

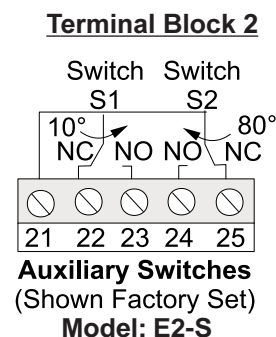

Auxiliary Switches
 (Shown Factory Set)
 Model: E2-S



Spring Return 24 VAC/VDC Electronic Actuators, Two-Position ES53A2(-S) & ES140A2(-S)

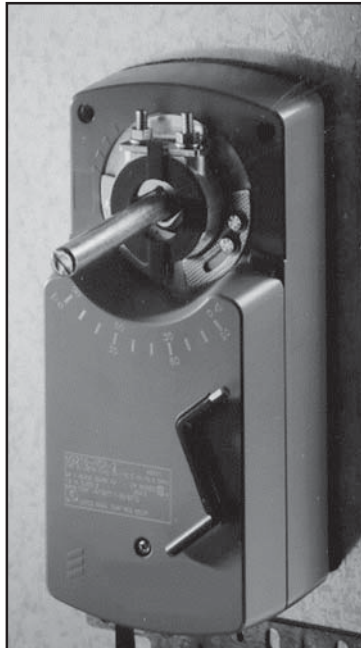

The ES “A” Series is a direct-mount, spring return line of electronic actuators that operates on 24 VAC or VDC power and is available for use with on/off controllers. These bidirectional actuators do not require a damper linkage and are easily installed on a round shaft up to 3/4” (20 mm) diameter or a square shaft up to 5/8” (16 mm). They can also be mounted to valves (ball, globe, and butterfly) using one of many valve linkage kits available through Dodge Engineering & Controls.

The ES models deliver up to 140 in-lb (16 N-m) of torque. The angle of rotation is mechanically adjustable. Integral auxiliary switches are available to indicate end-stop position or to perform switching functions at any angle within the selected rotation range. Position feedback is available through switches.

Torque Minimum: 53 in-lb (6 N-m) and 140 in-lb (16 N-m)

Application

ES actuators are designed to position air dampers and valves in HVAC systems. Applications include: positioning return air, exhaust or outdoor air dampers; controlling face and bypass dampers; positioning blades for variable volume fans; positioning ball, butterfly or globe valves. Refer to the manufacturer’s information to properly size the damper, valve and/or actuator.

Operation

ES53A2 and ES140A2 actuators operate on 24 VAC at 50/60 Hz or 24 VDC. They use a DC motor with stall detection circuitry that operates throughout the entire stroke. Rotation is mechanically limited to 93° by integral end-stops. The position of the actuator is visually indicated from 0° to 90° on the cover. An anti-rotation bracket prevents lateral movement of the actuator. On the ES140 actuator, the damper position can be set manually with the manual override feature in the event of a power failure.

Wiring

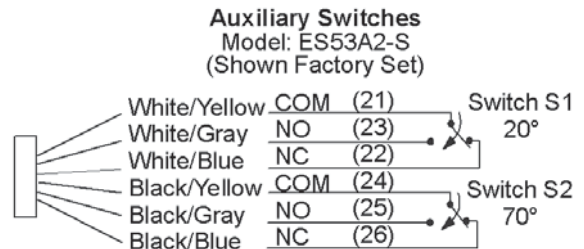
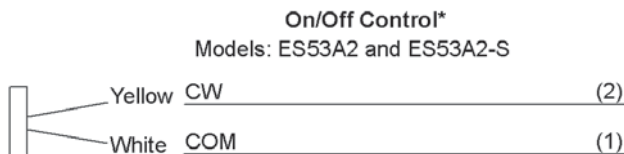



Spring Return 24 VAC/VDC Electronic Actuators, Two-Position ES53A2(-S) & ES140A2(-S)

Technical Data	ES53A2(-S)	ES140A2(-S)
Power supply	20 to 30 VAC @ 50/60 Hz or 24 VDC ±10%, class 2	
Transformer sizing	16 VA (32°F to 140°F) 22 VA (-22°F to 32°F) 25 VA (-40°F to -22°F) class 2 power source req. for UL	12 VA class 2 power source req. for UL
Electrical connection	48" cable, 20 AWG	screw terminals for 22 to 14 AWG
Control signal	20-30 VAC @ 50/60 Hz or 24 VDC ±10%	24 VAC @ 50/60 Hz or 24 VDC, 420 mA max.
Factory setting	pins 1&2, CW rotation	terminals 1&2, CW rotation
Feedback signal	-	-P: 1000 Ω, -P2: 185 Ω
Input impedance	voltage: 200 kΩ, current: 500 Ω	voltage: 205 kΩ, current: 500 Ω
Switch contact rating (-S option)		two SPDT rated @ 24 VAC, 1.5 A inductive, 3 A resistive (35 VA max/switch)
Mechanical connection (shaft size)	3/8" to 1/2" (10 mm to 12.7 mm) diameter round shaft 3/8" (10 mm) square shaft	3/8" to 3/4" (10 mm to 20 mm) diameter round shaft 3/8" to 5/8" (10 mm to 16 mm) square shaft
Angle of rotation	mechanically limited to 93°, adjustable from 34.5° to 90°	mechanically limited to 93°, adjustable from 30° to 90°
Torque	53 in-lbs (6 N-m)	140 in-lbs (16 N-m)
Direction of rotation	selectable with mounting position	selectable with coupler
Position indication	indicator	clip-on indicator
Running time	Non-spring return: 90 secs Spring return: NA	Non-spring return: 70 to 130 secs Spring return: <15 secs
Humidity	10 to 90% RH, non-condensing	0 to 95% RH, non-condensing
Ambient temperature	-40°F to 140°F (-40°C to 60°C)	-4°F to 122°F (-20°C to 50°C)
Storage temperature	-40°F to 186°F (-40°C to 86°C)	
Housing type*	NEMA 2 / IP42	
Agency listings	UL 873 listed; CSA C22.2 No. 139 Cert., CE Directive 89/336/EEC	
Noise level	≤45 dBA @ 1 m	
Servicing	maintenance free	
Quality standard	ISO 9002	
Weight	3.45 lbs (1.56 kg)	6.4 lbs (2.9 kg)

Wiring Diagrams

Terminal Block 1

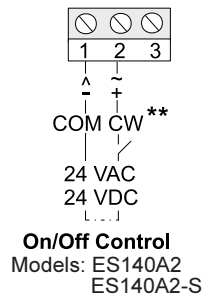

Terminal Block 2

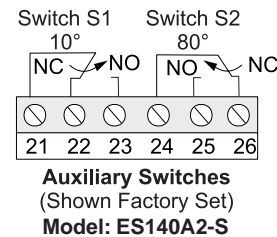

Notes:

- * Most commercial assemblies are available with an optional NEMA 4/4X type housing. See applicable data sheet for details.
- ** CW rotation for the 2-position models when the coupler is inserted in the front of the actuator, but CCW rotation when it is inserted in the back of the actuator.



Spring Return 120 VAC Electronic Actuators, Two-Position ES140A1(-S)

Components

The assembly consists of:

- ES140A2 without switches OR
- ES140A2-S with two auxiliary switches
- M9000-103 transformer
- M9000-100 conduit adaptor (two included with the ES140A1-S)

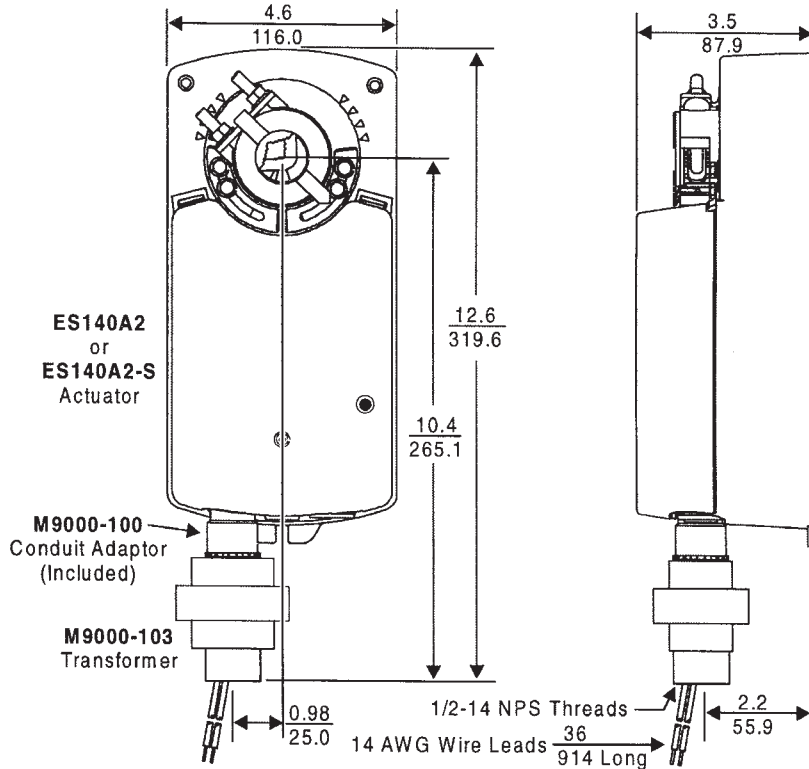

Assembly Dimensions, in. (mm)

Wiring Configuration

Primary	Secondary
Common, White	Common, Brown
120 VAC, Black	24 VAC, Orange

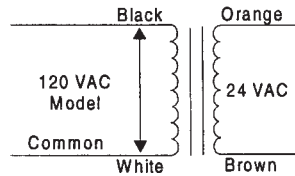

Transformer Wiring

Note:

- The ES140A1 and ES140A1-S power requirement is 14 VA at 120 VAC, 60 Hz.



Spring Return 24 VAC/VDC Electronic Actuators, Tri-State (Floating) ES53C2(-S), ES53C2-MP(-S) & ES140C2(-S), (-P), (-P2)

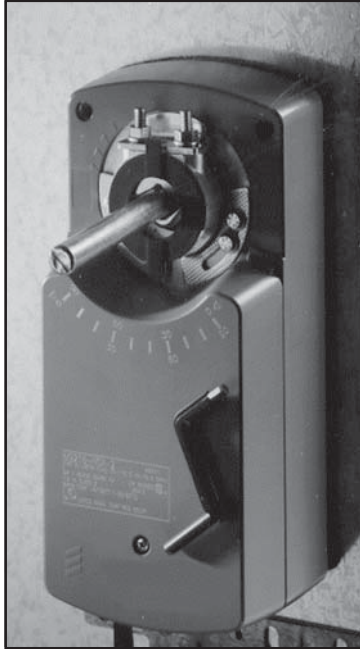

The ES53C2, ES53C2-MP and ES140C2 are direct-mount, spring return electronic actuators that operate on 24 VAC or VDC power and are available for use with floating controllers. These bidirectional actuators do not require a damper linkage. The ES140C2 is easily installed on a round shaft up to 3/4" (20 mm) diameter or a square shaft up to 5/8" (16 mm). The ES53C2 and ES53C2-MP can be installed on a round shaft up to 1/2" (13 mm) diameter or a square shaft up to 3/8" (10 mm). They can also be mounted to valves (ball, globe and butterfly) using one of many valve linkage kits available through Dodge Engineering & Controls.

The ES53C2 and ES53C2-MP models deliver 53 in-lb (6 N-m) of torque and the angle of rotation is adjustable in 10° increments. The ES140C2 model delivers 140 in-lb (16 N-m) of torque. The angle of rotation is mechanically adjustable from 30° to 90°. Integral auxiliary switches are available to indicate end-stop position or to perform switching functions at any angle within the selected rotation range. On the ES140C2, position feedback is available through switches, a potentiometer, or a 0 (2) to 10 VDC signal.

Torque Minimum: ES53C2 and ES53C2-MP: 53 in-lb (6 N-m); ES140C2: 140 in-lb (16 N-m)

Application: The actuators are designed to position air dampers and valves in HVAC systems. Applications include: positioning return air, exhaust or outdoor air dampers; controlling face and bypass dampers; positioning blades for variable volume fans; positioning ball, butterfly or globe valves. Refer to the manufacturer's information to size properly the damper, valve and/or actuator.

Operation: The actuators operate on 24 VAC at 50/60 Hz or 24 VDC. The ES53C2 and ES53C2-MP use a stepper motor with stall detection that operates throughout the entire stroke. The ES140C2 uses a DC motor with stall detection circuitry that operates throughout the entire stroke. The proportional actuators employ noise filtering techniques on the control signal to eliminate response to spurious noise. Rotation is mechanically limited to 93° by integral end-stops. The position of the actuator is visually indicated from 0° to 90° on the cover. An anti-rotation bracket prevents lateral movement of the actuator. The damper position can be set manually with the manual override feature in the event of a power failure.

Wiring Diagram: ES53C2(-S) and ES53C2-MP(-S)

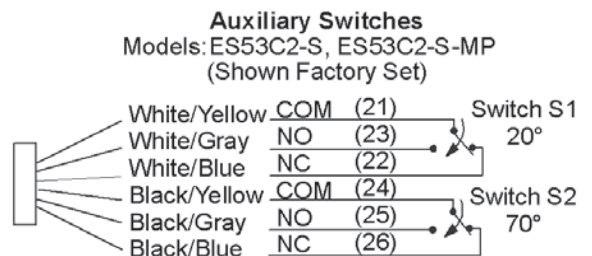
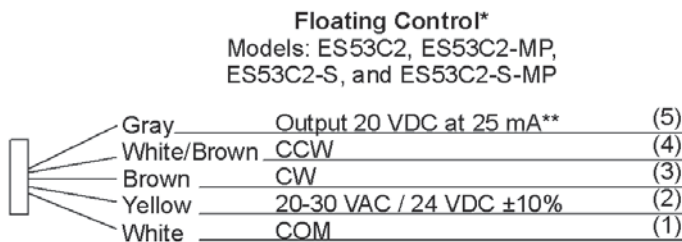

Notes:

- * CW becomes CCW, and CCW becomes CW when the actuator is mounted for CW spring return operation for both on/off and floating control.
- ** Only available on "-MP" models. Call DEI for details.



Spring Return 24 VAC/VDC Electronic Actuators, Tri-State ES53C2(-S), ES53C2-MP(-S) & ES140C2(-S), (-P), (-P2)

Technical Data	ES53C2(-S) & ES53C2-MP(-S)	ES140C2(-S)(-P)(-P2)
Power supply	20 to 30 VAC @ 50/60 Hz or 24 VDC ±10%	
Transformer sizing	16 VA min. at 32°F to 140°F (0°C to 60°C) 22 VA min. at -22°F to 32°F (-30°C to 0°C) 25 VA min. at -40°F to -22°F (-40°C to -30°C) class 2 power source req. for UL	12 VA class 2 power source req. for UL
Electrical connection	3 ft wire leads, 20 AWG cable	Screw terminals for 22 to 14 AWG
Control signal	20-30 VAC @ 50/60 Hz or 24 VDC ± 10%, 4.8 mA	24 VAC @ 50/60 Hz or 24 VDC, 4.8 mA
Factory setting	pins 1 & 3, CW rotation	terminals 1 & 3, CW rotation terminals 1 and 4, CCW rotation
Feedback signal	—	-P: 1000 Ω, -P2: 135 Ω
Input impedance	voltage: 200 kΩ, current: 500 Ω	voltage: 205 kΩ, current: 500 Ω
Switch contact rating (-S option)	two SPDT rated at 125/250 VAC, 5.8/2.9 A inductive, 1/4 hp	two SPDT rated at 24 VAC, 1.5 inductive, 3A resistive, 35 VA max./switch
Mechanical connection (shaft size)	1/2" (13 mm) diameter round shaft 3/8" (10 mm) square shaft	3/8" to 3/4" (10 mm to 20 mm) diameter round shaft 3/8" to 5/8" (10 mm to 16 mm) square shaft
Angle of rotation	mechanically limited to 93°, adjustable in 10° increments	mechanically limited to 93°, adjustable from 30° to 90°
Torque	53 in-lbs (6 N-m)	140 in-lbs (16 N-m)
Direction of rotation	selectable with coupler	
Position indication	clip-on indicator	
Running time	90 secs for 0-53 in-lbs (0 to 6 N-m)	Non-spring return: 70 to 130 secs for 0-140 in-lbs (0 to 16 N-m) Spring return: <15 secs
Humidity	10 to 90% RH, non-condensing	0 to 95% RH, non-condensing
Operating temperature	-40°F to 140°F (-40°C to 60°C)	-4°F to 122°F (-20°C to 50°C)
Storage temperature	-85°F to 190°F (-65°C to 88°C)	-40°F to 186°F (-40°C to 86°C)
Housing type*	NEMA 2, IP42	
Agency listings	UL873 listed, CSA C22.2 No. 139 Cert., CE Directive 89/336/EEC	
Noise level	≤45 dBA @ 1m	
Servicing	maintenance free	
Quality standard	ISO 9002	
Weight	3.45 lbs (1.56 kg)	6.4 lbs (2.9 kg)

Wiring Diagrams: ES140C2(-S), (-P), (-P2)

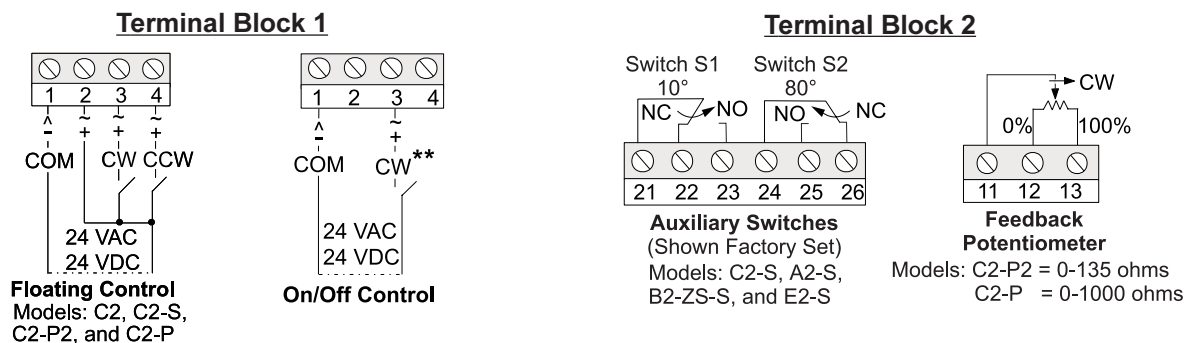

Notes:

- * Most commercial assemblies are available with an optional NEMA 4/4X type housing. See applicable data sheet for details.
- ** CW rotation for the On/Off models when the coupler is inserted in the front of the actuator, but CCW rotation when it is inserted in the back of the actuator.



Spring Return 24 VAC/VDC Electronic Actuators, Modulating ES53B2(-S), ES53B2-MP(-S) & ES140B2-ZS(-S)

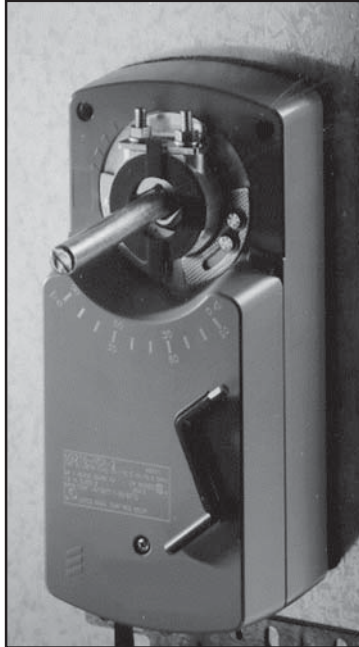

The ES53B2 and ES140B2 Series are a direct-mount, spring return line of electronic actuators that operate on 24 VAC or VDC power and are available for use with proportional controllers. These bidirectional actuators do not require a damper linkage. The ES53B2 can be installed on a round shaft up to 1/2" (13 mm) in diameter or a square shaft up to 3/8" (10 mm). The ES140B2 can be easily installed on a round shaft up to 3/4" (20 mm) diameter or a square shaft up to 5/8" (16 mm). They can also be mounted to valves (ball, globe, and butterfly) using one of many valve linkage kits available through Dodge Engineering & Controls.

The ES53B2 model delivers 53 in-lb (6 N-m) of torque. The rotation is mechanically adjustable in 10° increments. ES140B2 models deliver 140 in-lb (16 N-m) of torque. The angle of rotation is mechanically adjustable. Integral auxiliary switches are available to indicate end-stop position or to perform switching functions at any angle within the selected rotation range. Position feedback is available through switches or a 0 to 10 VDC signal.

Torque Minimum: ES53B2: 53 in-lb (6 N-m); ES140B2: 140 in-lb (16 N-m)

Application: The actuators are designed to position air dampers and valves in HVAC systems. Applications include: positioning return air, exhaust or outdoor air dampers; controlling face and bypass dampers; positioning blades for variable volume fans; positioning ball, butterfly or globe valves. Refer to the manufacturer's information to size properly the damper, valve and/or actuator.

Operation: The actuators operate on 24 VAC at 50/60 Hz or 24 VDC. The ES53B2 uses a stepper motor with stall detection that operates throughout the entire stroke. The ES140B2 uses a DC motor with stall detection circuitry that operates throughout the entire stroke. The proportional actuators employ noise filtering techniques on the control signal to eliminate response to spurious noise. Rotation is mechanically limited to 93° by integral end-stops. The position of the actuator is visually indicated from 0° to 90° on the cover. An anti-rotation bracket prevents lateral movement of the actuator. The damper position can be set manually with the manual override feature in the event of a power failure.

Wiring Diagram: ES53B2

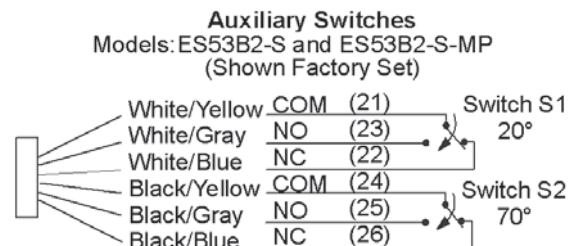
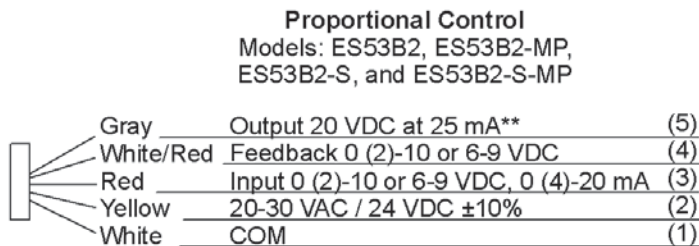

Note:

** For ES53B2-MP versions only. Call for details.



Spring Return 24 VAC/VDC Electronic Actuators, Modulating ES53B2(-S), ES53B2-MP(-S) & ES140B2-ZS(-S)

Technical Data	ES53B2(-S) & ES53B2-MP(-S)**	ES140B2-ZS(-S)
Power supply	20 to 30 VAC @ 50/60 Hz or 24 VDC ±10%	
Transformer sizing	16 VA min. at 32°F to 140°F (0°C to 60°C) 22 VA min. at -22°F to 32°F (-30°C to 0°C) 25 VA min. at -40°F to -22°F (-40°C to -30°C) class 2 power source req. for UL	12 VA class 2 power source req. for UL
Electrical connection	3-4 ft wire leads, 20 AWG cable	Screw terminals for 22 to 14 AWG
Control signal	Selectable: 0(2)-10 VDC or 0(4)-20 mA or 6-9 VDC	Selectable: 0(2)-10 VDC or 0(4)-20 mA
Control signal (-ZS option)	-	Adjustable: zero, 0-6 V (0-12 mA) span, 2-10 V (4-20 mA)
Factory setting	0-10 VDC, CW rotation with increase in signal (jumper selectable)	
Feedback signal	0 to 10 VDC or 6 to 9 VDC	0 to 10 VDC
Input impedance	voltage: 200 kΩ, current: 500 Ω	voltage: 205 kΩ, current: 500 Ω
Switch contact rating (-S option)	two SPDT double insulated 24 VAC, 50 VA pilot duty 120 VAC, 5.8 A resistive, 1/4 hp, 275 VA pilot duty 240 VAC, 2.9 A resistive, 1/4 hp, 275 VA pilot duty	two SPDT rated at 24 VAC, 1.5 A inductive, 3 A resistive, 35 VA max.
Mechanical connection (shaft size)	1/2" (13 mm) diameter, round shaft 3/8" (10 mm) square shaft	3/8" to 3/4" (10 mm to 20 mm) diameter, round shaft 3/8" to 5/8" (10 mm to 16 mm) square shaft
Angle of rotation	mechanically limited to 93°, adjustable in 10° increments	mechanically limited to 93°, adjustable from 30° to 90°
Torque	53 in-lbs (6 N-m)	140 in-lbs (16 N-m)
Direction of rotation	selectable with coupler	
Position indication	clip-on indicator	
Running time	90 secs for 0-53 in-lbs (0 to 6 N-m)	70 to 130 secs for 0-140 in-lbs (0 to 16 N-m)
Humidity	0 to 95% NH, non-condensing	
Ambient temperature	-40°F to 140°F (-40°C to 60°C)	-4°F to 122°F (-20°C to 50°C)
Storage temperature	-40°F to 190°F (-65°C to 88°C)	-40°F to 186°F (-40°C to 86°C)
Housing type*	NEMA 2, IP42	
Agency listing	UL873 listed, CSA C22.2 No. 139 Cert., CE Directive 89/336/EEC	
Noise level	≤45 dBA @ 1m	
Servicing	maintenance free	
Quality standard	ISO 9002	
Weight	3.45 lbs (1.56 kg)	6.4 lbs (2.9 kg)

Wiring Diagrams: ES140B2-ZS(-S)

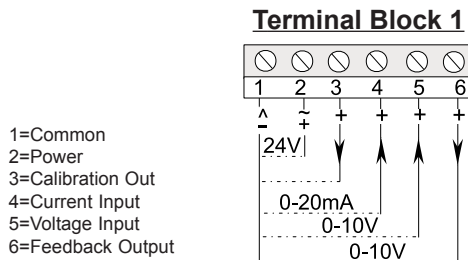

Proportional Control
Models: B2-ZS and B2-ZS-S

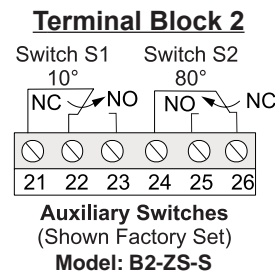

Notes:

- * Most commercial assemblies are available with an optional NEMA 4/4X type housing. See applicable data sheet for details.
- ** (-MP) version is available with 20 VDC at 25 mA auxiliary power output used to power external devices, such as thermostats and controllers.



Spring Return 24 VAC/VDC Electronic Actuators, Resistive ES140E2(-S)

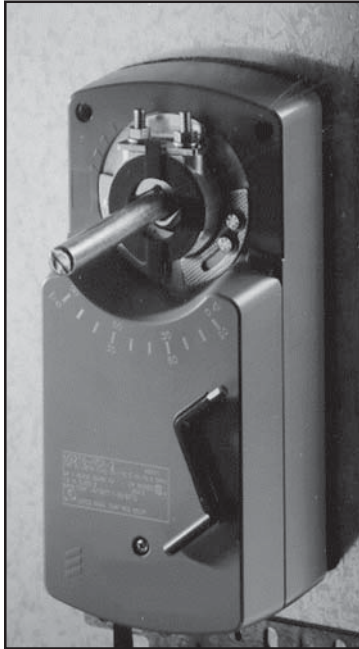

The ES140-E2 Series is a direct-mount, spring return line of electronic actuators that operates on 24 VAC or VDC power and is available for use with resistive controllers. These bidirectional actuators do not require a damper linkage and are easily installed on a round shaft up to 3/4" (20 mm) diameter or a square shaft up to 5/8" (16 mm). They can also be mounted to valves (ball, globe, and butterfly) using one of many valve linkage kits available through Dodge Engineering & Controls.

The ES140E2 models deliver 140 in-lb (16 N-m) of torque. The angle of rotation is mechanically adjustable from 30° to 90°. Integral auxiliary switches are available to indicate end-stop position or to perform switching functions at any angle within the selected rotation range. Position feedback is available through switches or a 0 (2) to 10 VDC signal.

Torque Minimum: 140 in-lb (16 N-m)

Application: ES actuators are designed to position air dampers and valves in HVAC systems. Applications include: positioning return air, exhaust or outdoor air dampers; controlling face and bypass dampers; positioning blades for variable volume fans; positioning ball, butterfly or globe valves. Refer to the manufacturer's information to size properly the damper, valve and/or actuator.

Operation: ES actuators operate on 24 VAC at 50/60 Hz or 24 VDC. They use a DC motor with stall detection circuitry that operates throughout the entire stroke. The resistive actuators employ noise filtering techniques on the control signal to eliminate response to spurious noise. Rotation is mechanically limited to 93° by integral end-stops. The position of the actuator is visually indicated from 0° to 90° on the cover. An anti-rotation bracket prevents lateral movement of the actuator. The damper position can be set manually with the manual override feature in the event of a power failure.



Spring Return 24 VAC/VDC Electronic Actuators, Resistive ES140E2(-S)

Technical Data	ES140E2
Power supply	20 to 30 VAC @ 50/60 Hz or 24 VDC ±10%
Transformer sizing	12 VA class 2 power source req. for UL
Electrical connection	Screw terminals for 22 to 14 AWG
Control signal	Resistive: 100 to 10,000 Ω
Factory setting	CW rotation with increase in signal (jumper selectable)
Feedback signal	0 to 10 VDC for 90° (1 mA at 10 VDC)
Input impedance	1.8 M Ω
Switch contact rating	two SPDT rated at 24 VAC, 1.5 inductive, 3A resistive, 35 VA max.
Mechanical connection (shaft size)	3/8" to 3/4" (10 mm to 20 mm) diameter, round shaft 3/8" to 5/8" (10 mm to 16 mm) square shaft
Angle of rotation	mechanically limited to 93°, adjustable from 30° to 90°
Torque	140 in-lbs (16 N-m)
Direction of rotation	selectable with coupler
Position indication	clip-on indicator
Running time	70 to 130 secs for 0-140 in-lbs (0 to 16 N-m)
Humidity	0 to 95% NH, non-condensing
Ambient temperature	-4°F to 122°F (-20°C to 50°C)
Storage temperature	-40°F to 186°F (-40°C to 86°C)
Housing type*	NEMA 2, IP42
Agency listing	UL873 listed, CSA C22.2 No. 139 Cert., CE Directive 89/336/EEC
Noise level	≤45 dBA @ 1m
Servicing	maintenance free
Quality standard	ISO 9002
Weight	6.4 lbs (2.9 kg)

Wiring Diagrams

Terminal Block 1

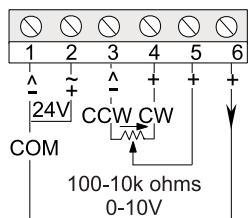

Resistive Input Control
Models: E2 and E2-S

Note:

Terminals 3 and 4 function as CCW and CW references when the Resistive models are in the DA mode, but as CW and CCW references when these models are in the RA mode.

Terminal Block 2

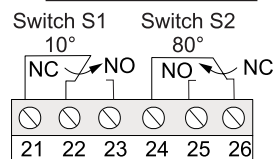

Auxiliary Switches
(Shown Factory Set)
Model: E2-S

Note:

* Most commercial assemblies are available with an optional NEMA 4/4X type housing. See applicable data sheet for details.



Electronic Commercial Actuators Type B

Commercial Actuator Selection Chart

– Non-Spring Return	AC-B-1
– Spring Return	AC-B-2
Non-Spring Return, 24 VAC, Tri-State/Two-Position, EN35C2-N & EN35C2-NDP	AC-B-3-4
Non-Spring Return, 24 VAC, Tri-State/Two-Position, EN53A2(-S), EN53C2(-S); EN70C2, EN140C2, EN210C2 & EN280C2(-S), (-P), (-P2)	AC-B-5-7
Non-Spring Return, 24 VAC/VDC, Modulating, EN53B2(-S), EN70B2(-S)(-ZS), EN140B2(-S)(-ZS), EN210B2(-S)(-ZS) & EN280B2(-S)	AC-B-8-10
Non-Spring Return, 24 VAC/VDC, Resistive, EN70E2(-S), EN140E2(-S) & EN210E2(-S)	AC-B-11-12
Spring Return, 24 VAC/VDC, Two-Position, ES53A2(-S) & ES140A2(-S)	AC-B-13-14
Spring Return, 120 VAC, Two-Position, ES140A1(-S)	AC-B-15
Spring Return, 24 VAC/VDC, Tri-State (Floating), ES53C2(-S), ES53C2-MP(-S) & ES140C2(-S), (-P), (-P2)	AC-B-16-17
Spring Return, 24 VAC/VDC, Modulating, ES53B2(-S), ES53B2-MP(-S) & ES140B2-ZS(-S)	AC-B-18-19
Spring Return, 24 VAC/VDC, Resistive, ES140E2(-S)	AC-B-20-21



How to Select the Commercial Electronic Actuator Part Number

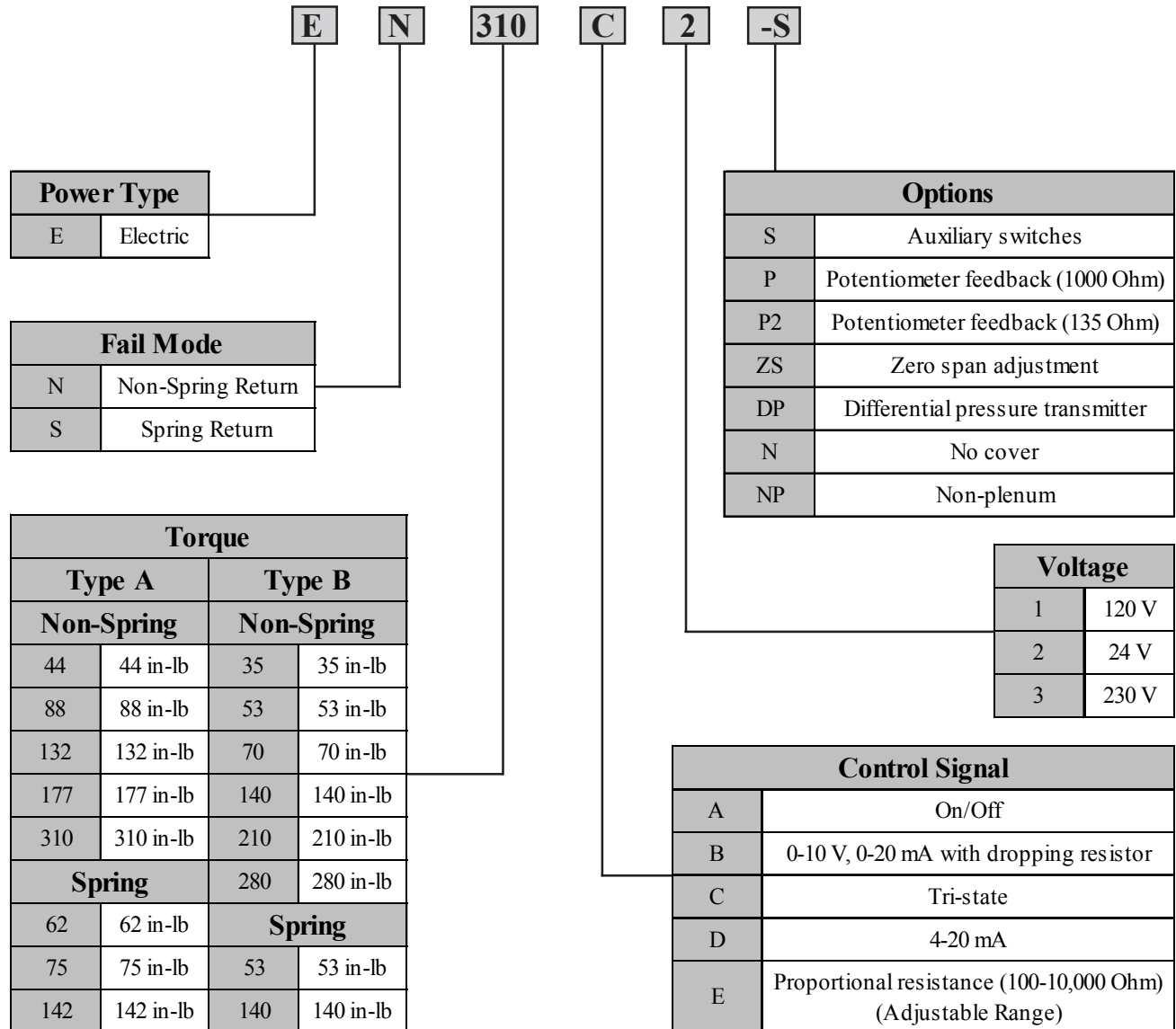

Note:

- See Actuator Selection Chart to confirm combinations.